



Gaceta
CCH

Suplemento
3 de mayo de 2024

TRABAJOS DE MANTENIMIENTO INVIERNO 2023



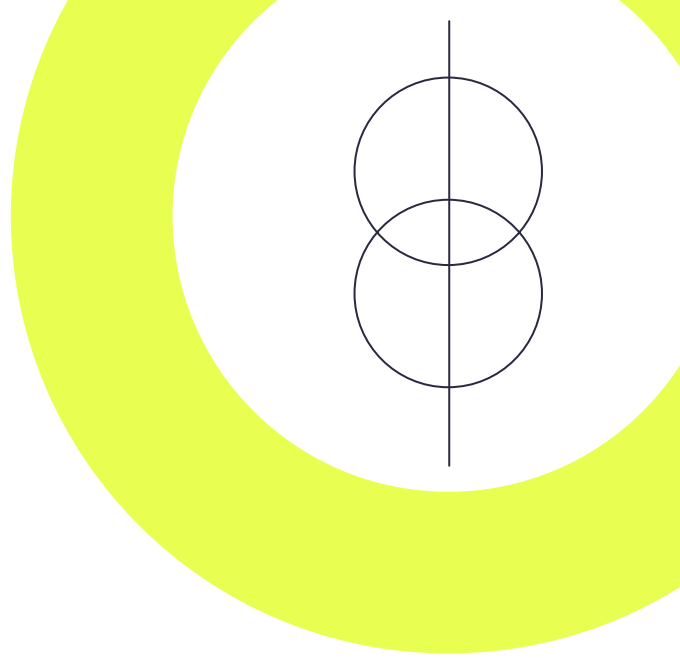
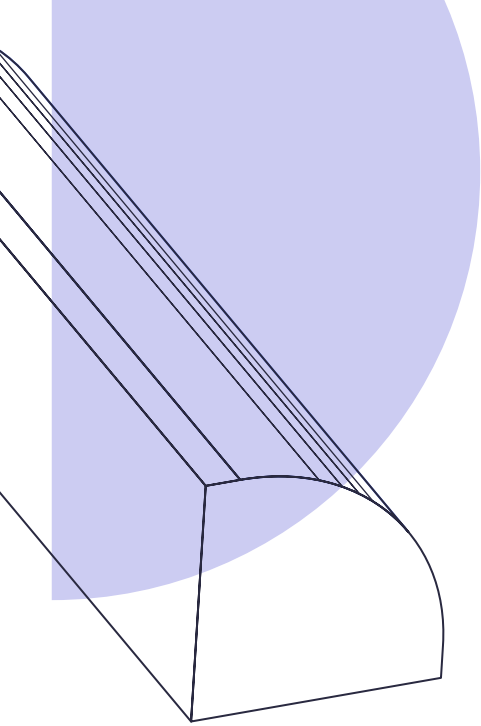

ÍNDICE

PRESENTACIÓN	3
JUSTIFICACIÓN	5
DIRECCIÓN GENERAL	7
PLANTEL AZCAPOTZALCO	30
PLANTEL NAUCALPAN	41
PLANTEL VALLEJO	67
PLANTEL ORIENTE	83
PLANTEL SUR	94

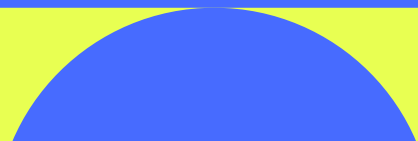
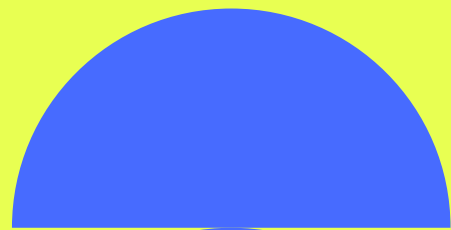
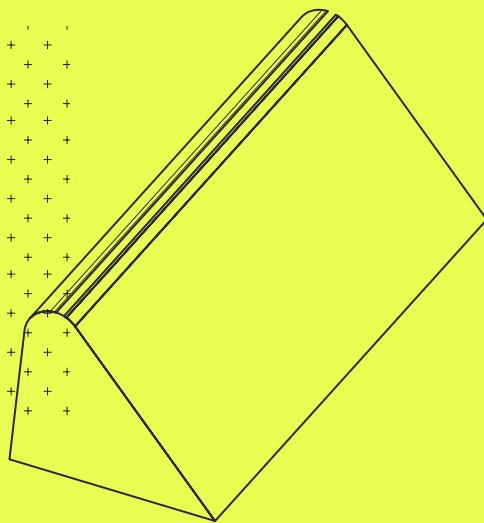
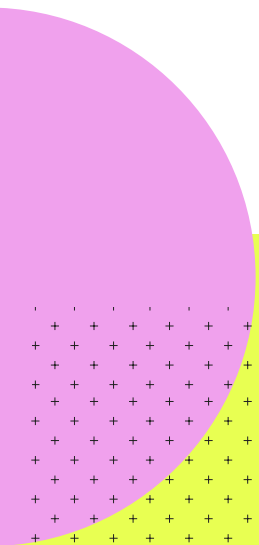

PRESENTACIÓN

La mayoría de las instalaciones de los cinco planteles del Colegio de Ciencias y Humanidades tiene más de 50 años de existencia, por lo cual requieren de trabajos de prevención y mantenimiento para asegurar las mejores condiciones de uso de los edificios, salones, auditorios, gimnasios, bibliotecas, laboratorios, entre otros espacios.

En este contexto, se presentan a continuación las acciones llevadas a cabo en el marco del Programa de Mantenimiento de Invierno 2023, en los ámbitos de mantenimiento de los sistemas hidráulicos, sanitarios, eléctricos, de gas, de telecomunicaciones e internet.

En este periodo, se desarrollaron 21 trabajos en las sedes de Dirección General del CCH; 10 en Azcapotzalco; 20 en Naucalpan; 15 en Vallejo; 10 en Oriente y 18 en Sur. Entre ellas destacan impermeabilizaciones, poda de árboles, arreglos de baños y dernajes; obras de cancelería, herrería, colocación de pisos y diversos trabajos de limpieza.

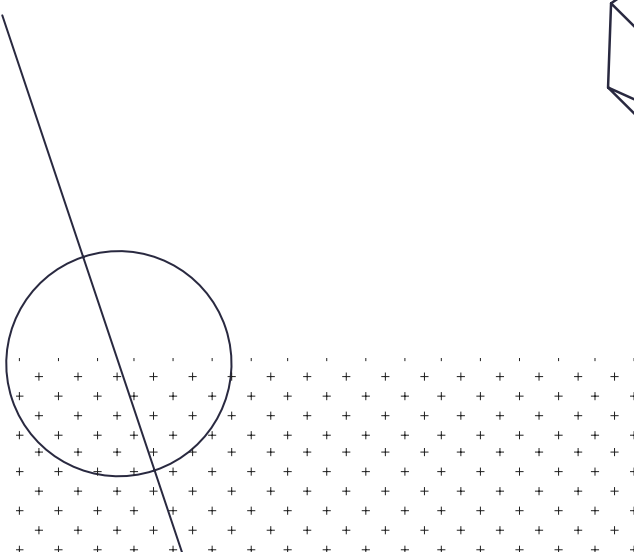
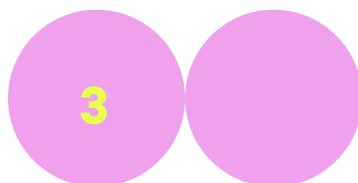
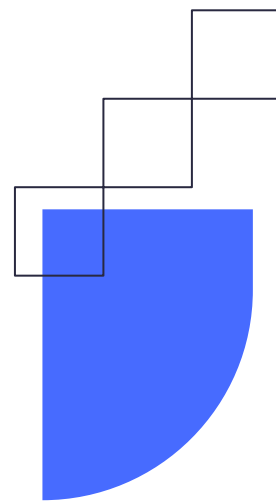
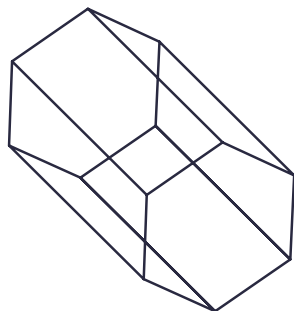

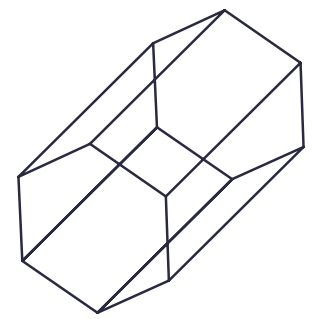

Los trabajos del Programa de Mantenimiento de Invierno 2023 se llevaron a cabo con el apoyo de la Secretaría Administrativa de la Dirección General del Colegio, la Superintendencia de Obras y las secretarías administrativas de cada uno de los planteles. Agradecemos a todas y todos los que participaron en estas tareas que favorecen las funciones sustantivas de docencia, investigación y e extensión académica, cultural y recreativa.

Dr. Benjamín Barajas Sánchez
DIRECTOR GENERAL DEL
COLEGIO DE CIENCIAS Y HUMANIDADES

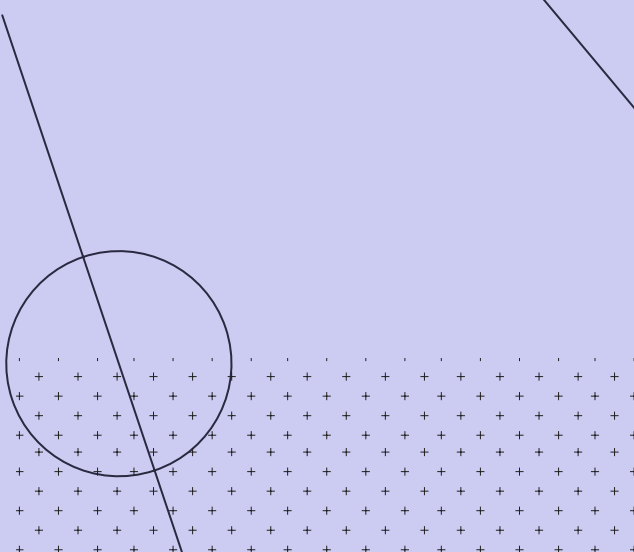
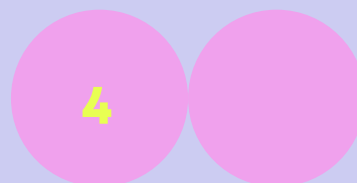
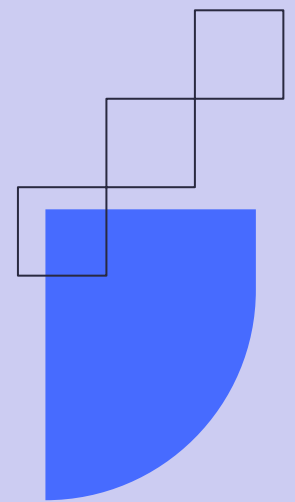
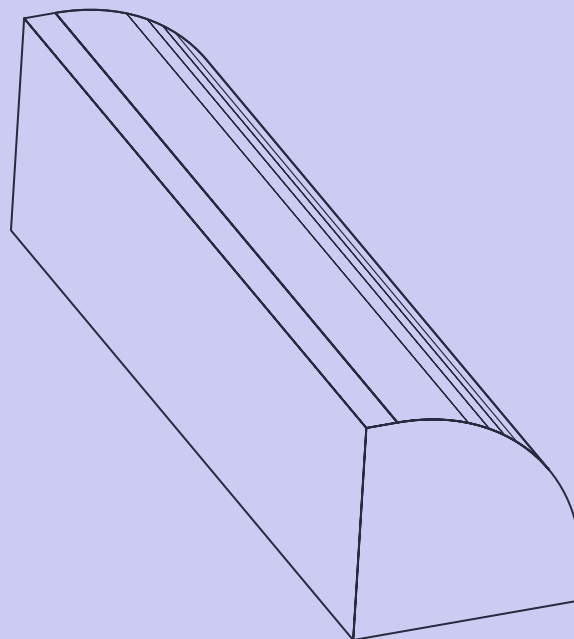

JUSTIFICACIÓN

Al hablar de mantenimiento y conservación de las instalaciones de los planteles del Colegio de Ciencias y Humanidades inmediatamente se asocia con el uso constante de los inmuebles que conforman la infraestructura. Debido a esto se implementan acciones para conservarlos en un estado óptimo para el usuario, por esto se realizan los servicios de mantenimiento: hidráulico, sanitario, eléctrico, de telecomunicaciones, red y de gas, por mencionar algunos. Planeando adecuadamente los servicios y obras periódicamente, se permite contar con instalaciones más seguras, útiles y sustentables, por la intensa labor diaria en los planteles, los cuales cuentan con más de 50 años de antigüedad.

Para ello es necesario elaborar un cronograma que asegure contar con las instalaciones idóneas, así como con los requerimientos necesarios para su correcto funcionamiento y que garanticen confort para los usuarios. Debido a esto, se pretende que, en su mayoría, los mantenimientos a las instalaciones se realicen de manera organizada y preventiva, antes de atender de manera correctiva las necesidades que se presentan.

La Dirección General del Colegio de Ciencias y Humanidades, a través de su Secretaría Administrativa y de la Superintendencia, sabe de la importancia de brindar el servicio de forma preventiva y programada, para cumplir con las exigencias y necesidades que requiere cada plantel.

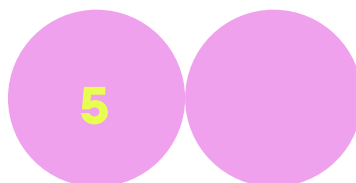
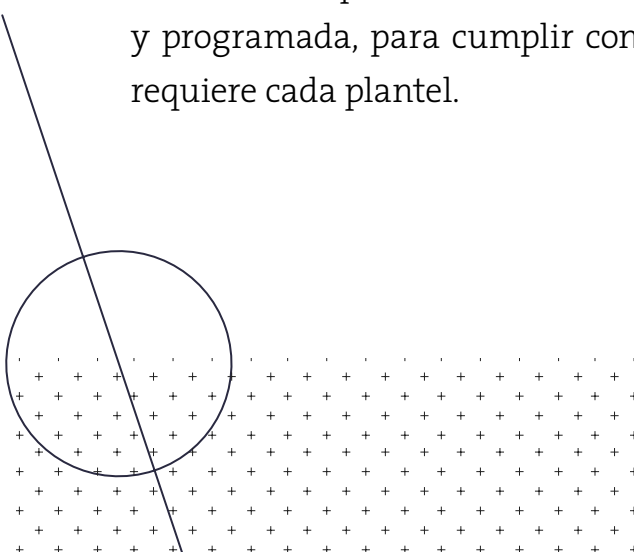
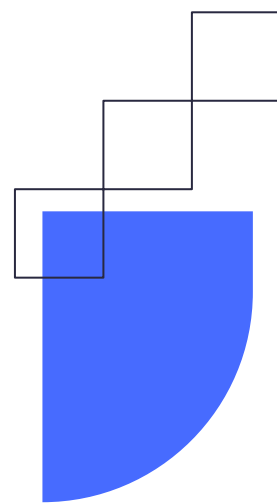
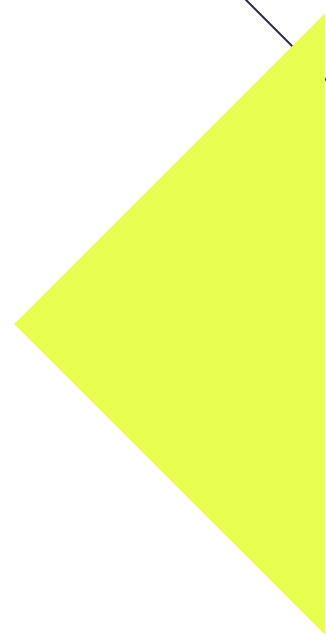
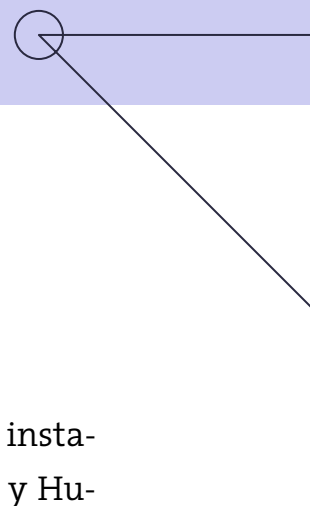

DIAGNÓSTICO

El diagnóstico de los requerimientos obedece al análisis de cada uno de los espacios para el adecuado reingreso de las actividades y el mantenimiento programado de los equipos hidráulicos, sanitarios, drenaje, eléctricos y de telecomunicaciones, así como mantenimientos básicos de pintura, rehabilitaciones, readecuaciones, remodelaciones, proyectos nuevos en los espacios académicos, lúdicos o recreativos como multicanchas y gimnasios al aire libre.

El diagnóstico de necesidades tiene como meta principal ser la vía que permita realizar de manera planificada los programas de mantenimiento, por antecedentes, contando con conocimientos análogos e históricos para la resolución de una problemática en particular, consultando a los responsables de cada plantel. Los trabajos deberán contar con la correcta descripción de las acciones para su adecuada instalación y funcionamiento, derivado de un análisis y diagnóstico previo de las necesidades particulares de cada plantel del Colegio.

El buen análisis de los trabajos permitirá que el catálogo de conceptos de cada obra describa los mejores escenarios, para que los trabajos programados den confort y la seguridad de lograr la operación de las instalaciones e infraestructura de los planteles, para que todas las actividades cotidianas de la comunidad académica se lleven a cabo.

A continuación, se describen los trabajos realizados en el Programa de Mantenimiento de Invierno 2023.

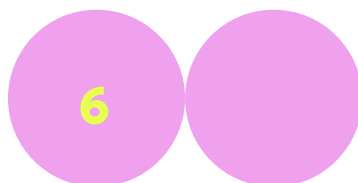
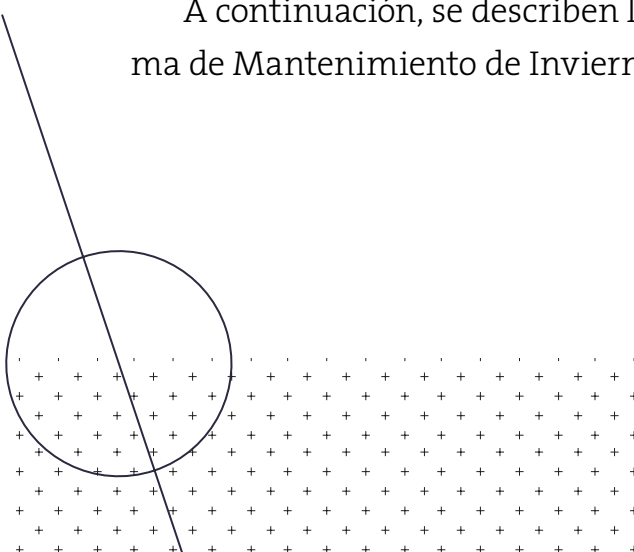
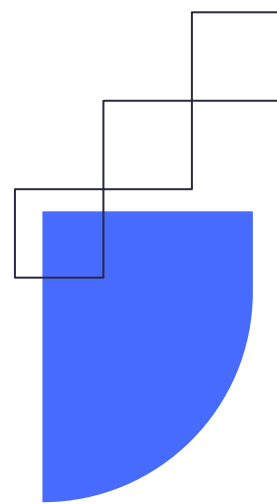
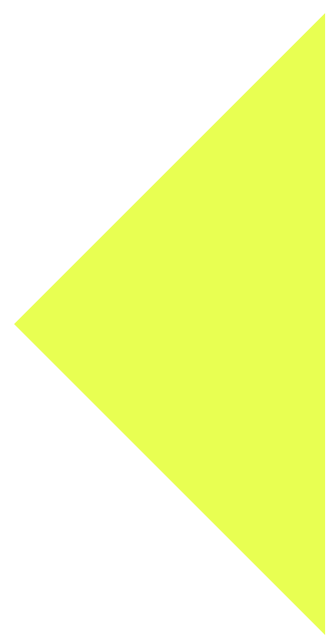

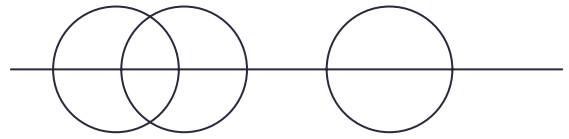
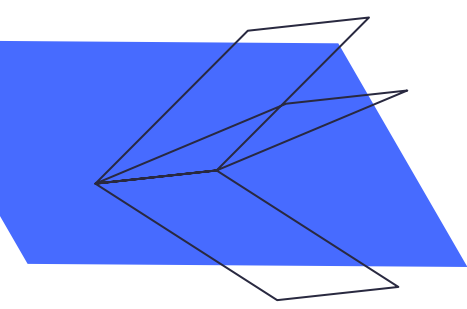

DIRECCIÓN GENERAL

Se realizó mantenimiento en la Dirección General del Colegio de Ciencias y Humanidades en sus sedes Circuito, Universidad 3000 y Laboratorio Central. Estas acciones permiten el buen funcionamiento de las distintas instalaciones para la realización de las actividades del CCH.

Para el periodo de invierno, se llevó a cabo el cambio de 172.47 m² del piso de la Sala del Consejo Técnico de la Dirección General, además se aplicaron 735.57 m² de pintura en oficinas de Secretaría Administrativa y Salas y 250 m² de pintura de líneas de estacionamiento. Asimismo, se realizó la sustitución de 10 cámaras de vigilancia en sede de Universidad 3000.

Acciones

1. Cambio de 172.47 m² de piso en Sala de Consejo de la Dirección General.
2. Sustitución de tableros y cableado eléctrico, áreas planta baja desde Presupuesto a Movimientos Académicos. Incluye balanceo de cargas.
3. Cambio de alerta sísmica y colocación de 3 bocinas en sede Circuito.
4. Mantenimiento de 13 muebles de madera en área de Planeación.
5. Mantenimiento a 9 puertas de madera y 21 de cancelería de primero y segundo pisos en sede Circuito.

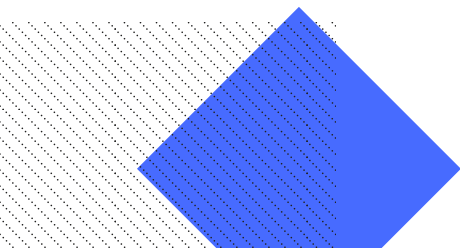

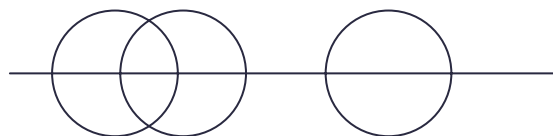
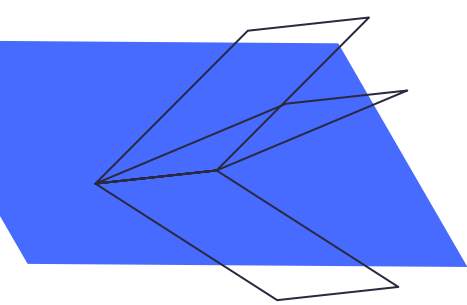

6. Mantenimiento y sustitución de 9 cámaras de vigilancia en sede Circuito.
7. Sustitución de 10 cámaras de vigilancia en sede Universidad 3000.
8. Aplicación de 8.40 m² de pintura en puerta norte en sede Circuito.
9. Aplicación de 19.80 m² de pintura en letras “CCH 50” en sede Circuito.
10. Aplicación de 735.57 m² de pintura en oficinas de la Secretaría Administrativa y Salas.
11. Aplicación de 250 m² de pintura de líneas de estacionamiento de la Dirección General.
12. Aplicación de 1,353.41 m² de pintura en oficinas de primer piso en sede Universidad 3000.
13. Aplicación de 8.94 m² de pintura en área de baños y oficina de la Superintendencia de Obras en sede Laboratorio Central.
14. Cambio de pintura tipo alberca en cisterna.
15. Aplicación de 370.66 m² de pintura en fachadas norte, sur y este.
16. Suministro y colocación de 10 m² de piso epóxico en área de sustancias.
17. Aplicación de 6 m² de pintura de señalética de seguridad.
18. Colocación de bota-aguas en la Superintendencia de Obras, en sede Laboratorio Central.
19. Instalación de HDMI y Audio en Dirección General (CCH TV).
20. Cambio de cubierta de Laboratorio Central.
21. Sustitución y reconexión de intercomunicador en Avenida del Imán 5 Bis.

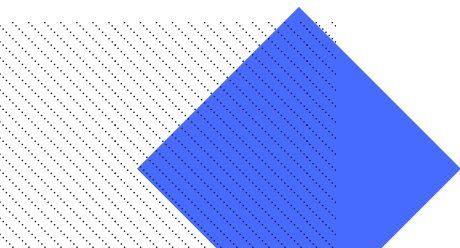

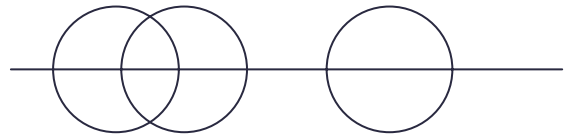
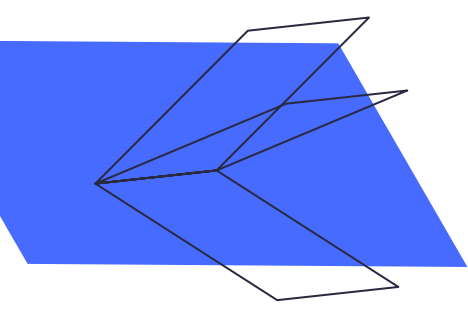

1. Cambio de 172.47 m² de piso en Sala de Consejo de la Dirección General.

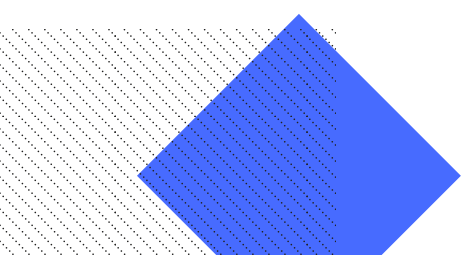

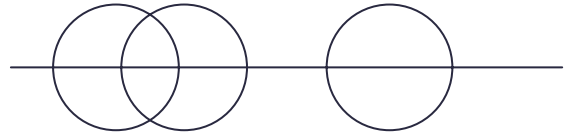
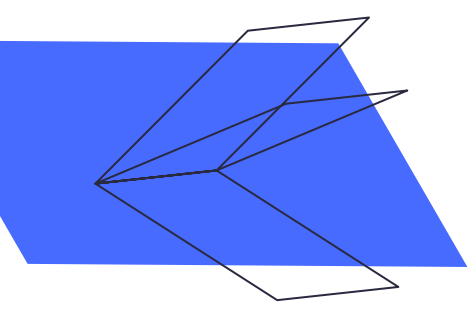

2. Sustitución de tableros y cableado eléctrico, áreas planta baja desde Presupuesto a Movimientos Académicos.

Incluye balanceo de cargas.

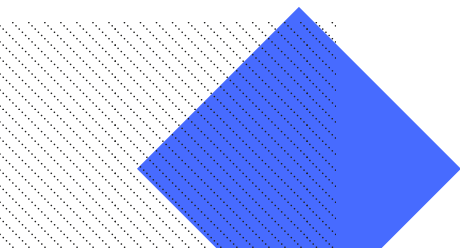
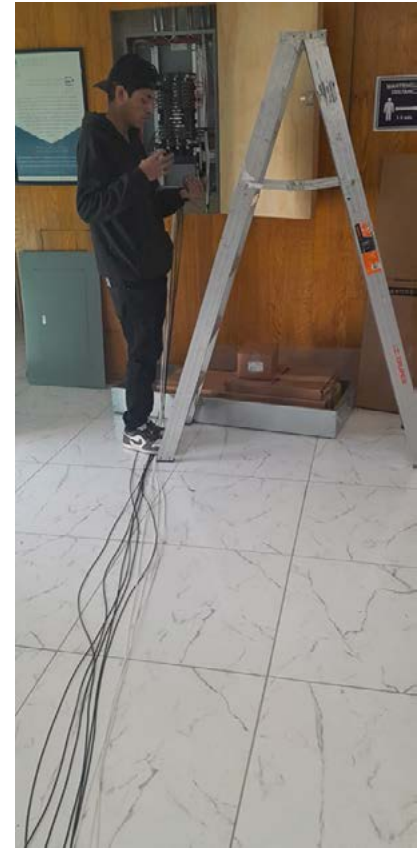

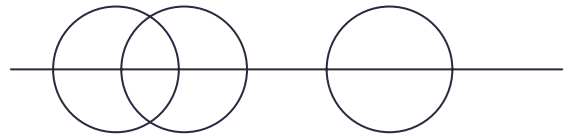
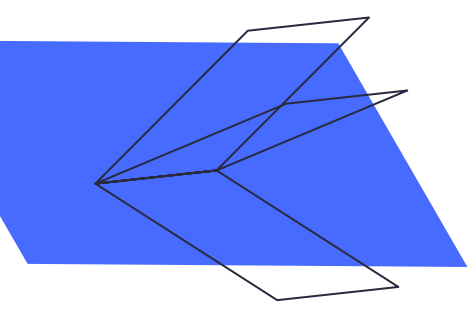

3. Cambio de alerta sísmica y colocación de 3 bocinas en sede Circuito.

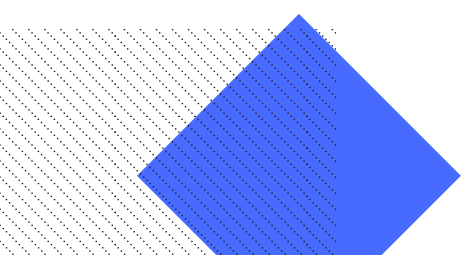
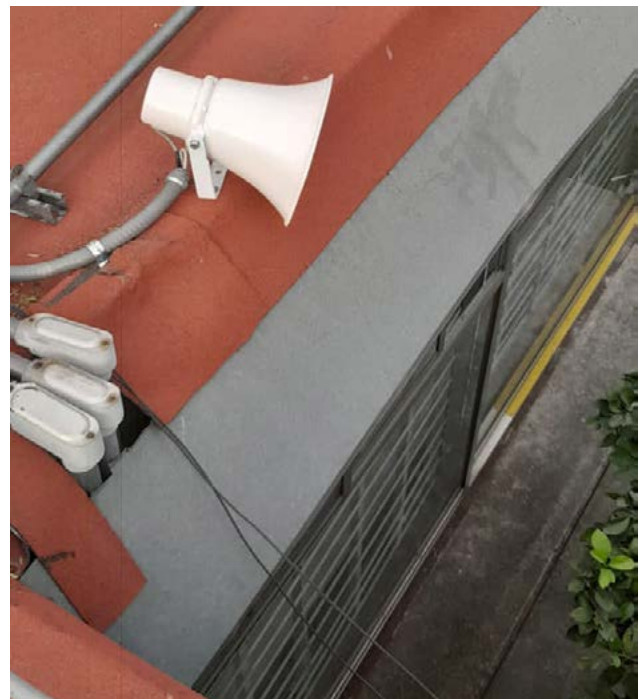

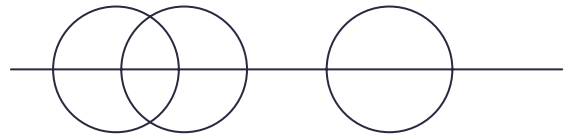
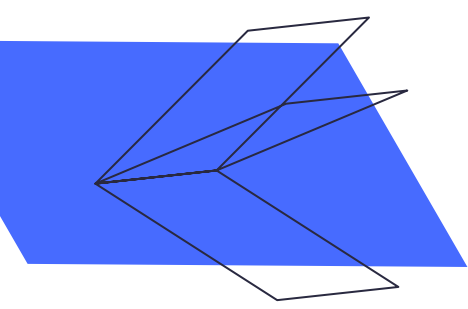

4. Mantenimiento de 13 muebles de madera en el área de Planeación.

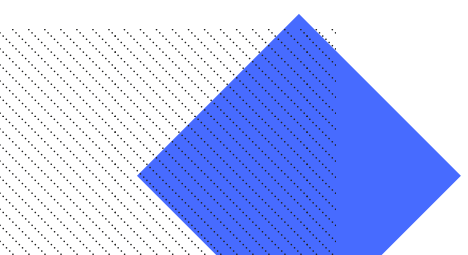

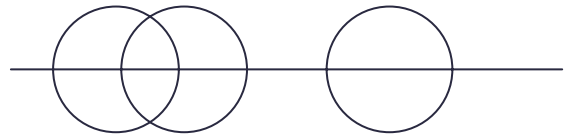
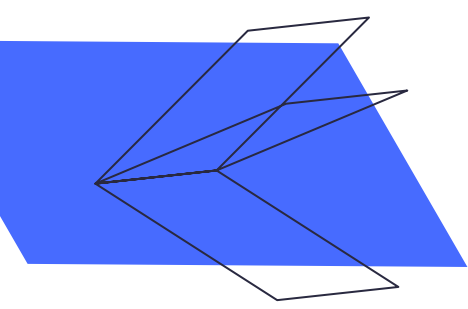

5. Mantenimiento a 9 puertas de madera y 21 de cancelería de primero y segundo pisos en sede Circuito.

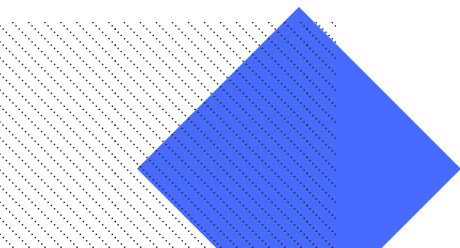

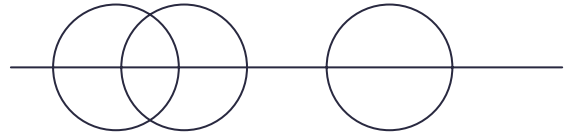
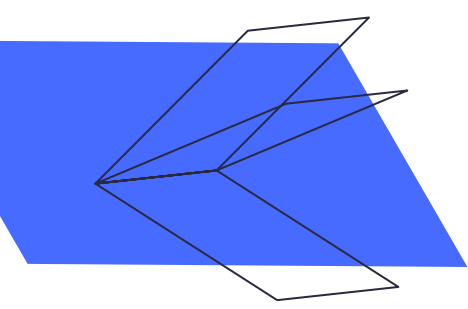

6. Mantenimiento y sustitución de 9 cámaras de vigilancia en sede Circuito.

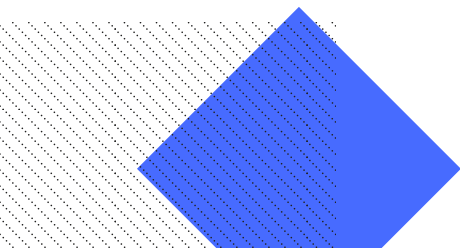

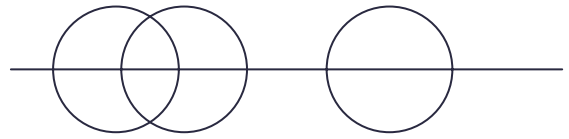
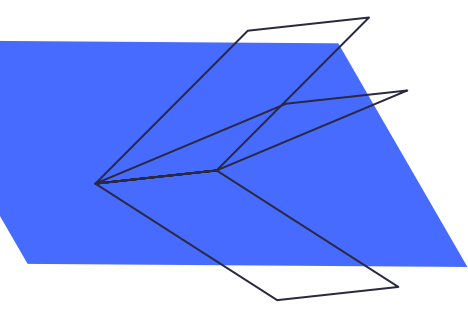

7. Sustitución de 10 cámaras de vigilancia en sede Universidad 3000.

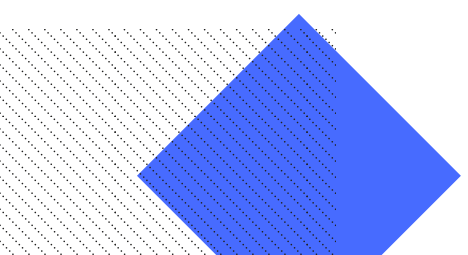

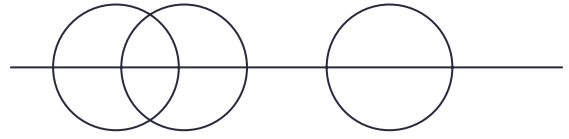
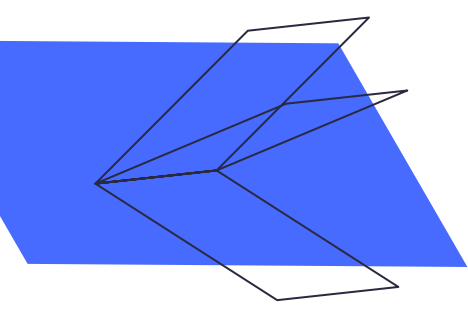

8. Aplicación de 8.40 m² de pintura en puerta norte en sede Circuito.

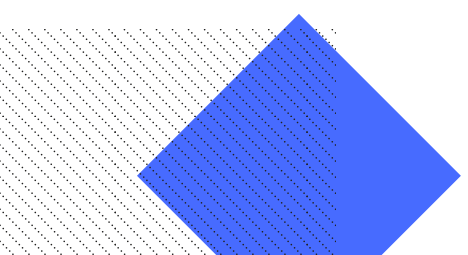

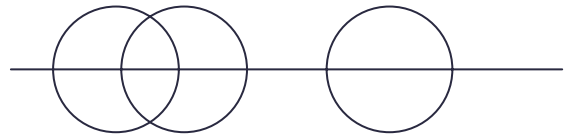
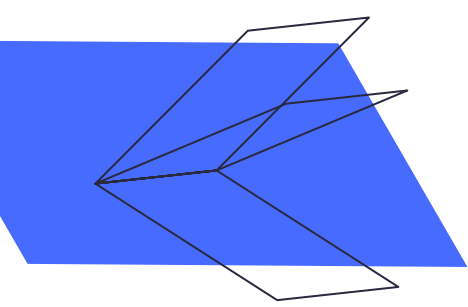

9. Aplicación de 19.80 m² de pintura en letras “CCH 50” en sede Circuito.

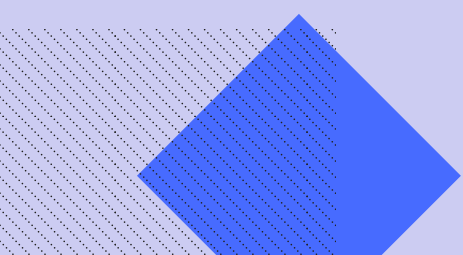
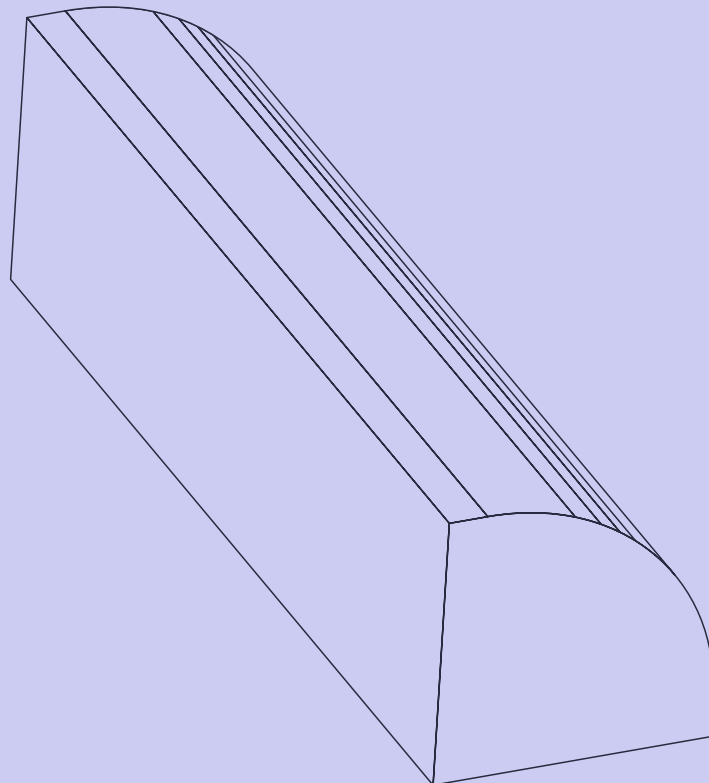

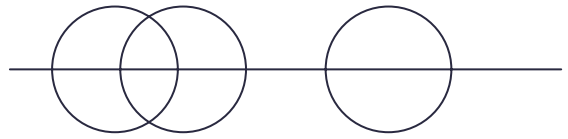
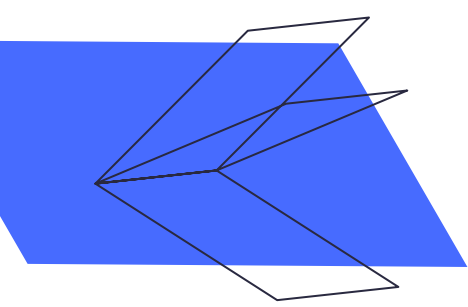

10. Aplicación de 735.57 m² de pintura en oficinas de la Secretaría Administrativa y Salas.

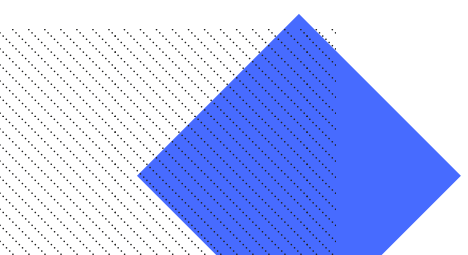

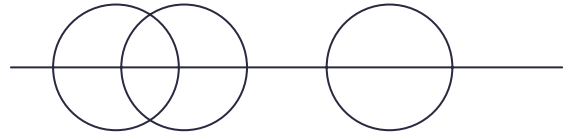
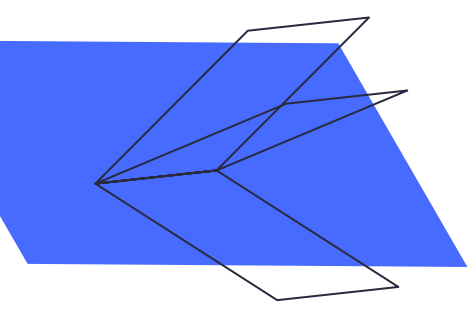

11. Aplicación de 250 m² de pintura de líneas de estacionamiento de la Dirección General.

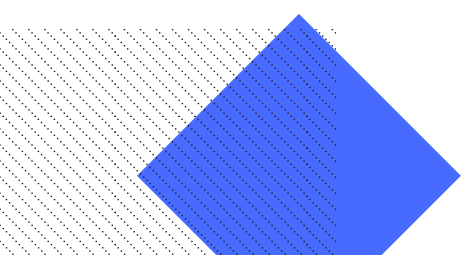
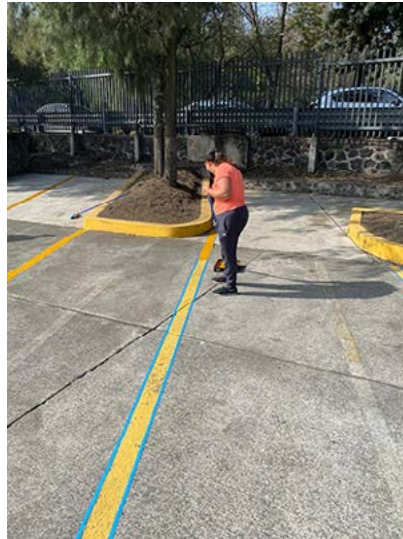

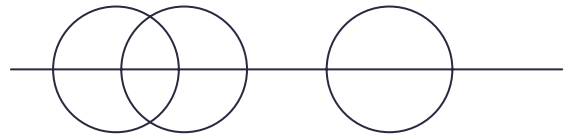
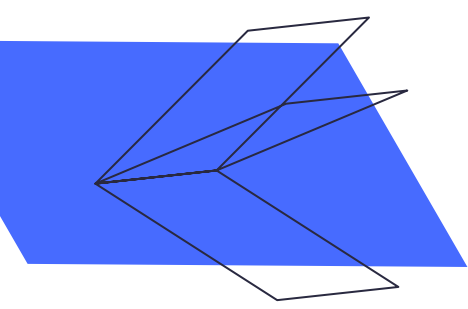

12. Aplicación de 1,353.41 m² de pintura en oficina de primer piso en sede Universidad 3000.

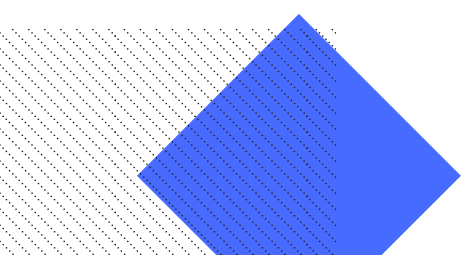

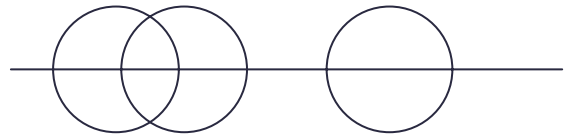
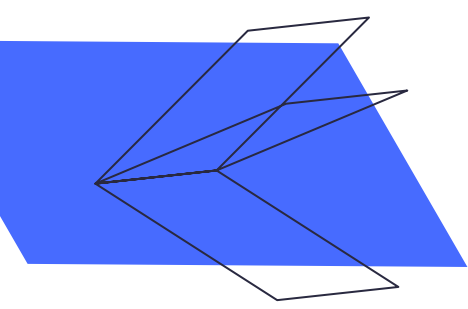

13. Aplicación de 8.94 m² de pintura en área de baños y oficina de la Superintendencia de Obras, en sede Laboratorio Central.

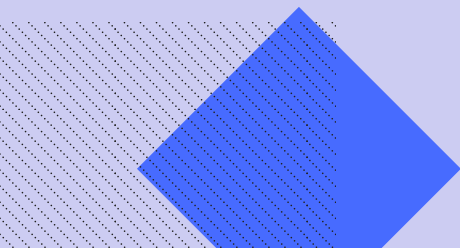
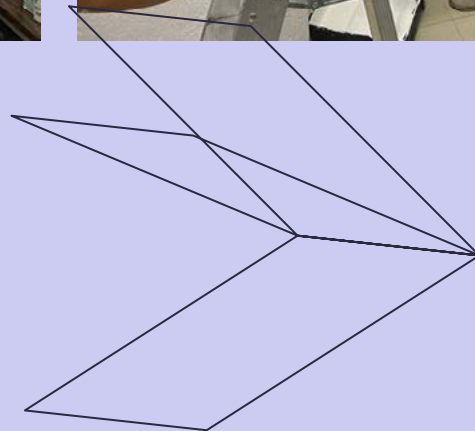

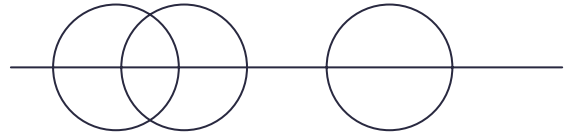
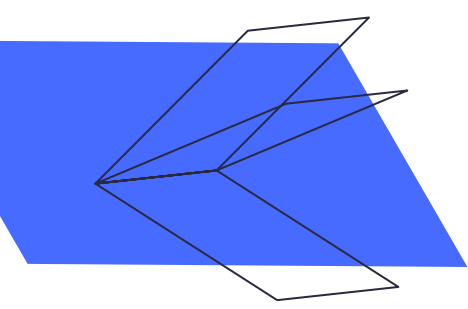

14. Cambio de pintura tipo alberca en cisterna.

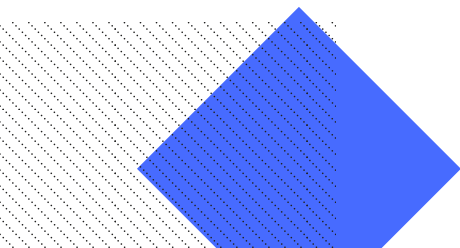

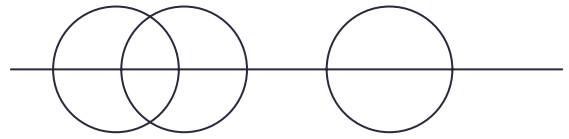
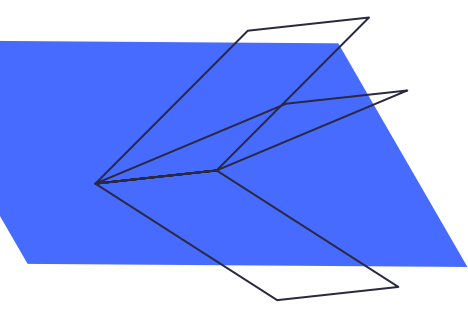

15. Aplicación de 370.66 m² de pintura en fachadas norte, sur y este.

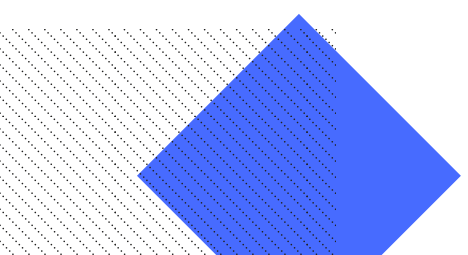

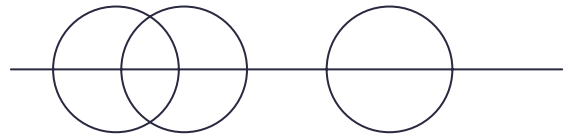
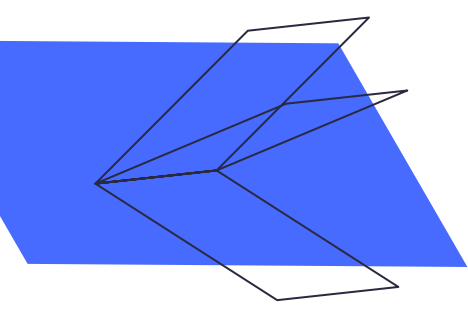

16. Suministro y colocación de 10 m² de piso epóxico en área de sustancias.

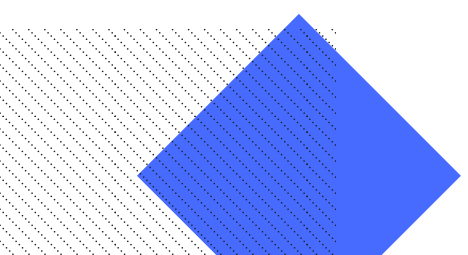

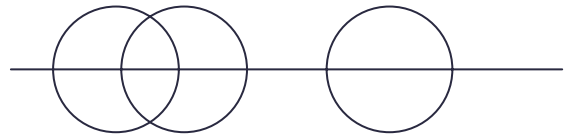
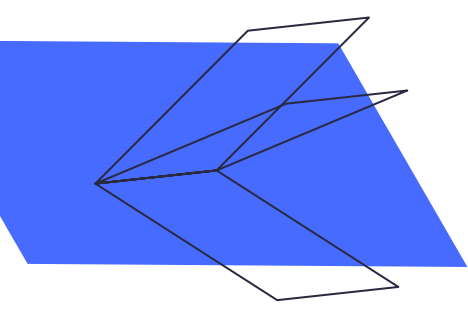

17. Aplicación de 6 m² de pintura de señalética de seguridad.

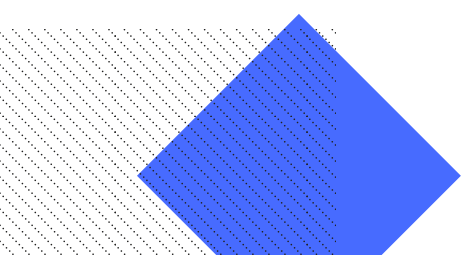

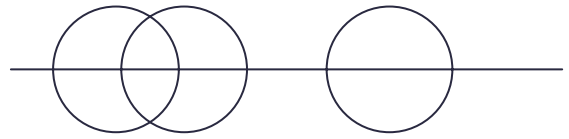
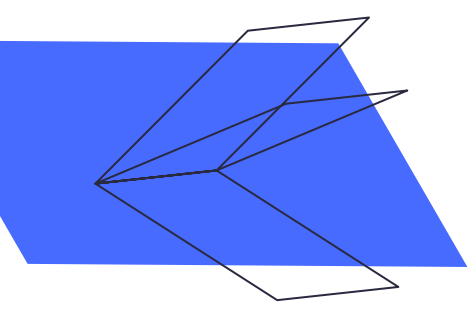

18. Colocación de bota-aguas en la Superintendencia de Obras, en sede Laboratorio Central.

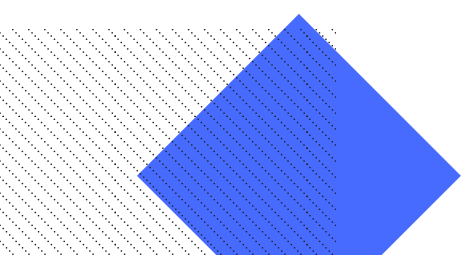

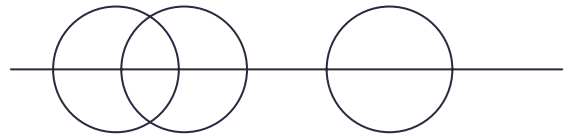
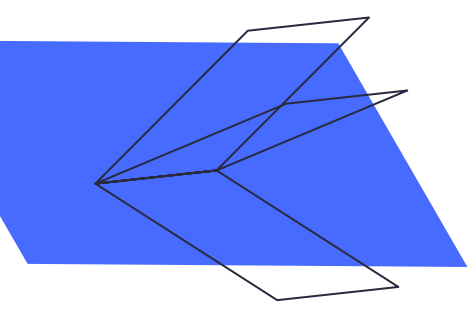

19. Instalación de HDMI y Audio en la Dirección General (CCH TV).

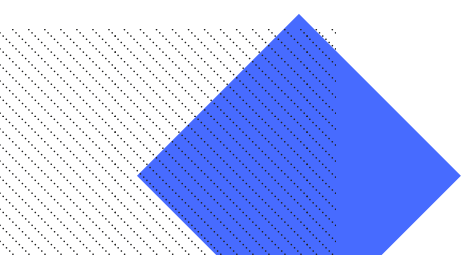
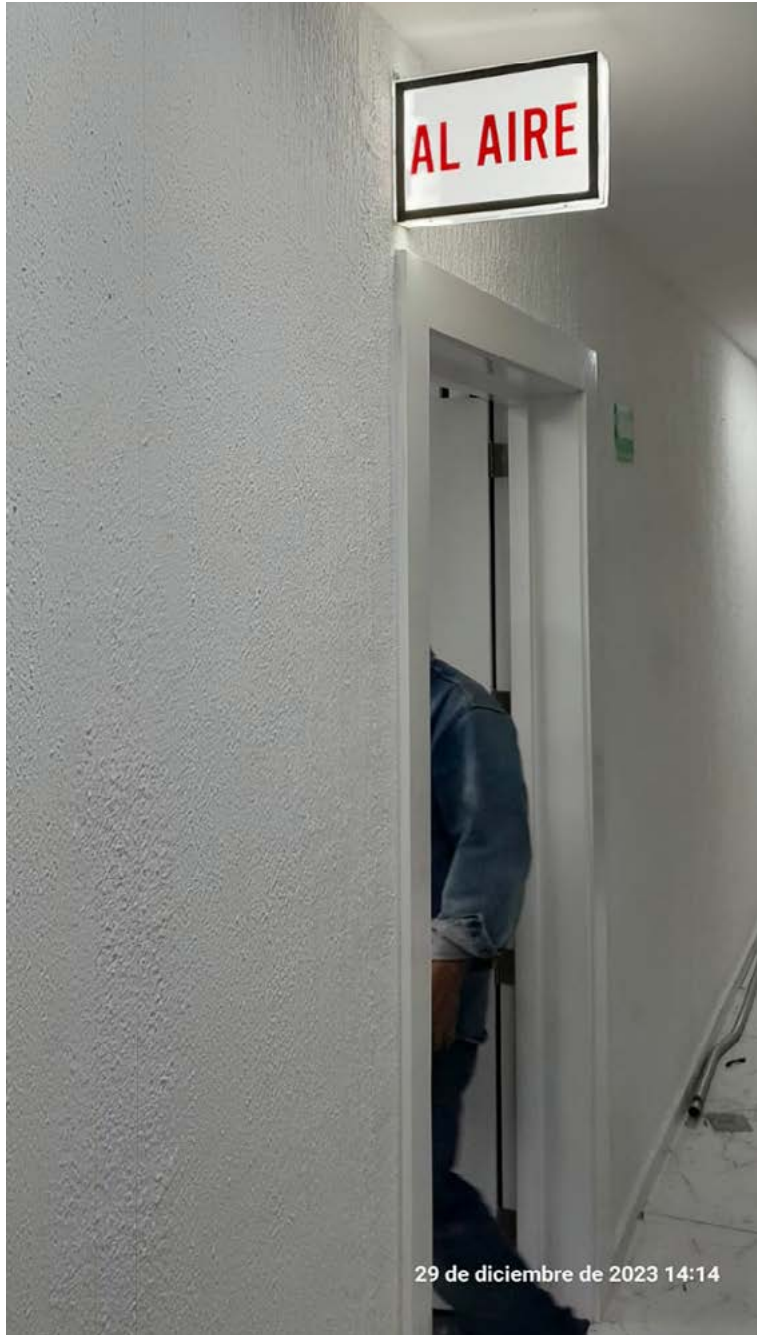

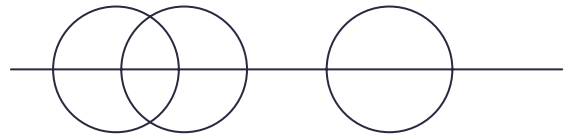
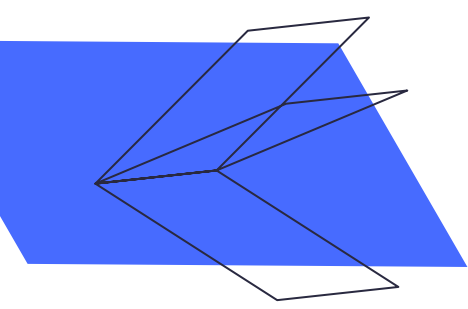

20. Cambio de cubierta de Laboratorio Central.

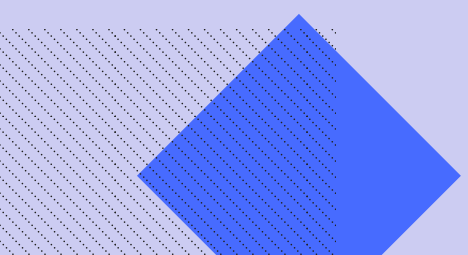
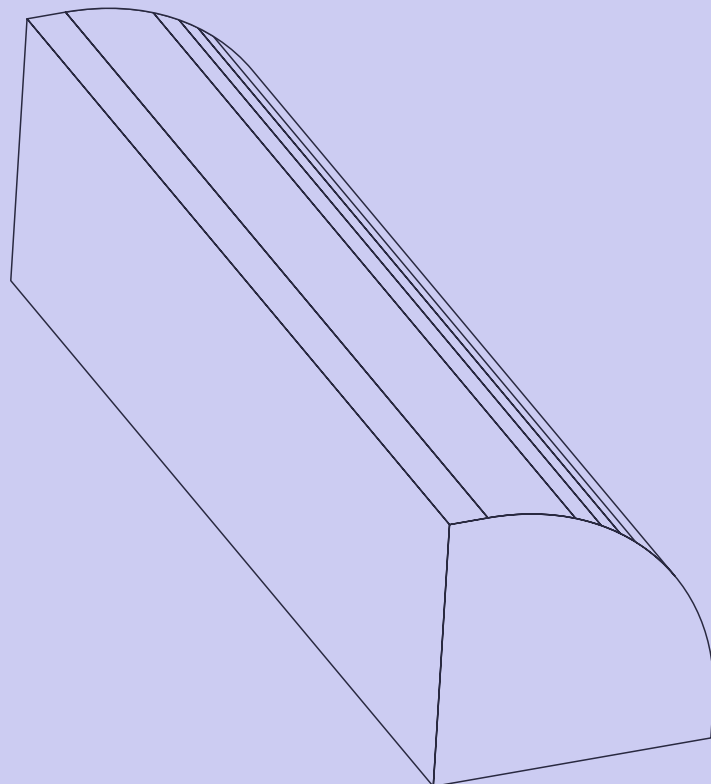

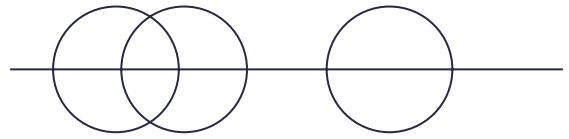
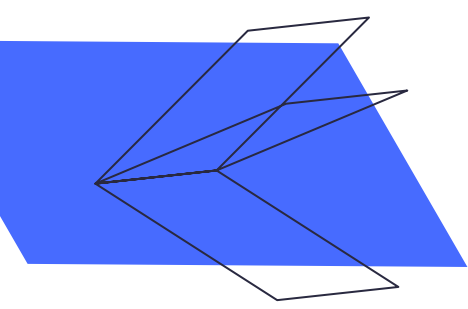

21. Sustitución y reconexión de intercomunicador en Avenida del Imán 5 Bis.

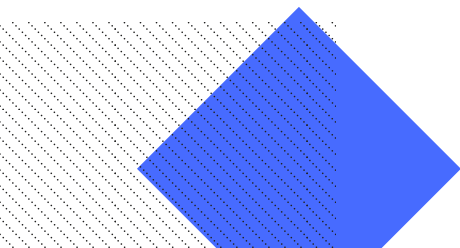

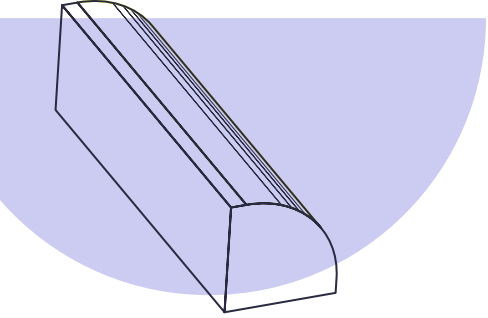

PLANTEL AZCAPOTZALCO

En el plantel Azcapotzalco se realizó la rehabilitación del edificio de la Dirección para tenerlo en completo funcionamiento. También se aplicó la impermeabilización correspondiente al edificio de Audiovisual y el ex-comedor, y se realizaron las protecciones de herrería necesarias para los edificios de la Imprenta y K.

Acciones

1. Poda alta y baja de 76 árboles.
2. Limpieza de 420 m² de aulas Azc 1, 2 y 3.
3. Impermeabilización de 1,115 m² de Audiovisual.
4. Impermeabilización de 156 m² de ex-comedor.
5. Pintura en 1,470 m² en edificios M, O, K e Imprenta.
6. Pintura en 706 m² en bancas de concreto.
7. Pintura en 272 m² en barandales de las jardineras.
8. Protecciones de herrería en edificios Imprenta y K.
9. Mantenimiento a 100 mesas binarias.
10. Rehabilitación de edificio de la Dirección.

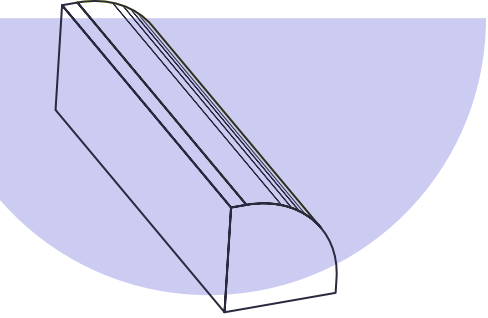

1. Poda alta y baja de 76 árboles.

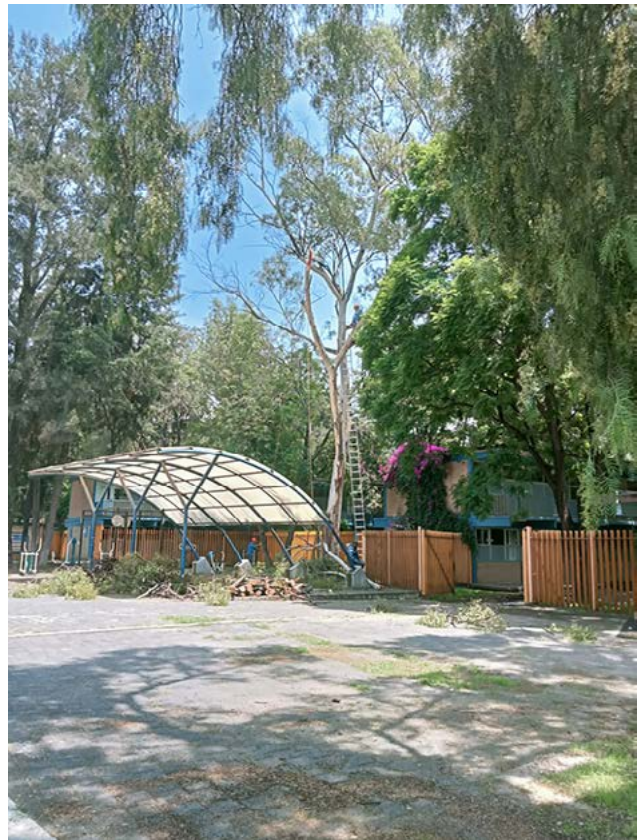

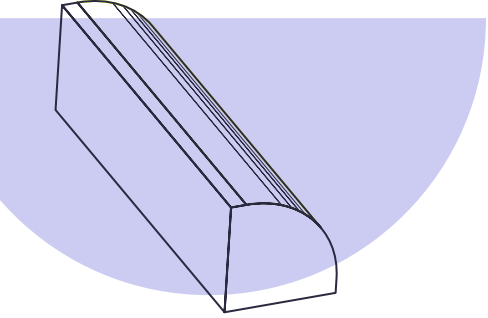

2. Limpieza de 420m² de aulas Azc 1, 2 y 3.



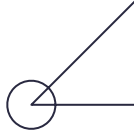
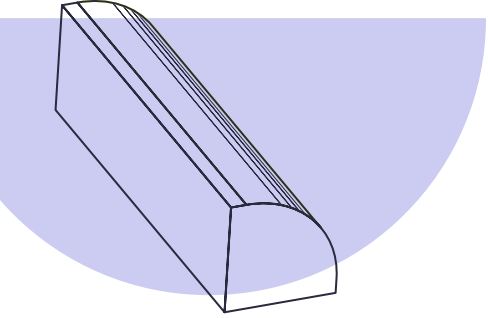

3. Impermeabilización de 1,115 m² de Audiovisual.



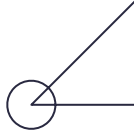
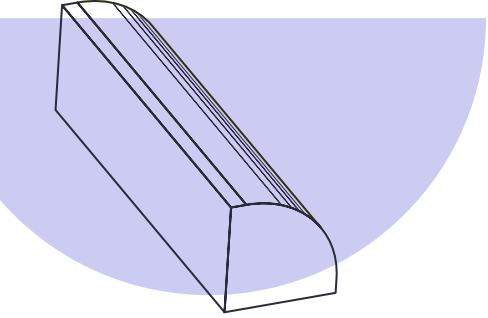

4. Impermeabilización de 156 m² de ex-comedor.



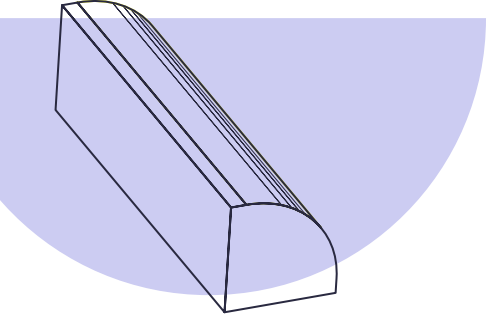

5. Pintura en 1,470 m² en edificios M, O, K e Imprenta.



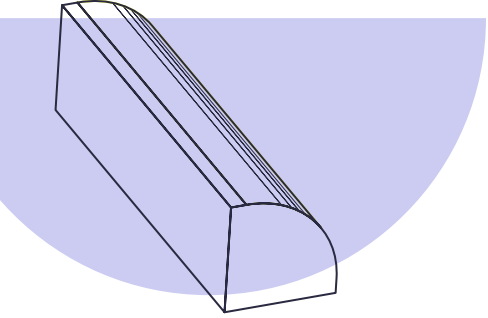

6. Pintura en 706 m² en bancas de concreto.



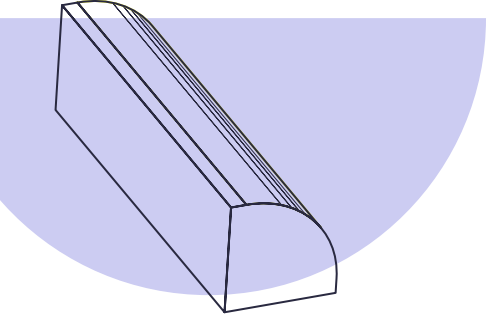

7. Pintura en 272 m² en barandales de las jardineras.



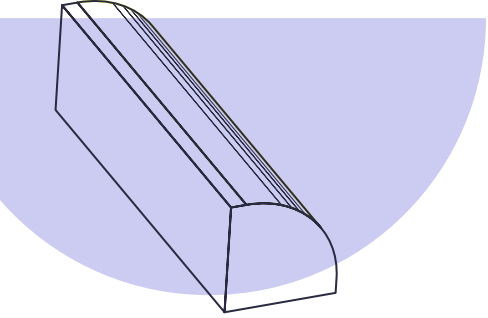

8. Protecciones de herrería en edificios Imprenta y K.



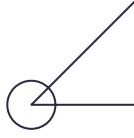
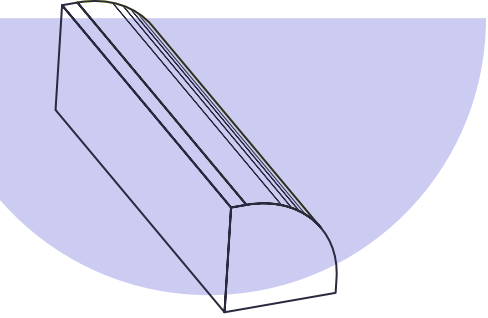

9. Mantenimiento a 100 mesas binarias.



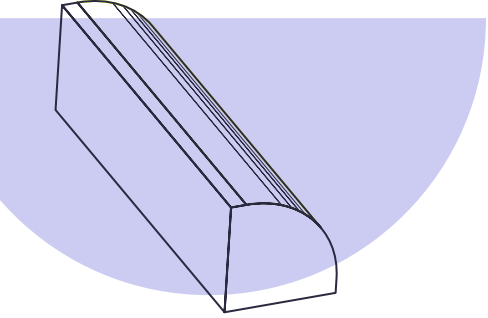

10. Rehabilitación de edificio de la Dirección.

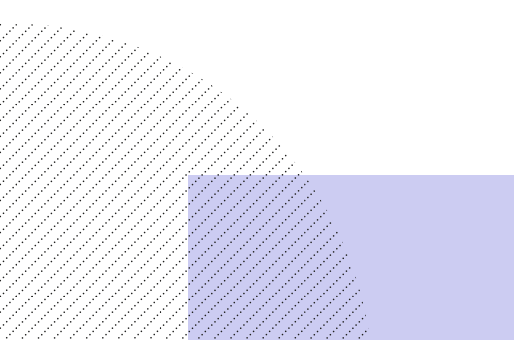

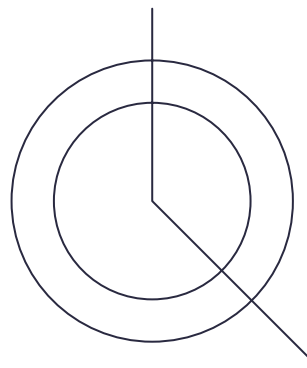
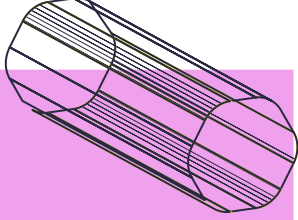

PLANTEL NAUCALPAN

En el plantel Naucalpan destaca el mantenimiento a rampas de acceso para personas con discapacidad, a material de biblioteca, a sanitarios, barras de lavabo en sanitario y a cuarto oscuro de fotografía. También se hizo una limpieza profunda a 582.62 m² de cancelería y herrería; se instalaron 10 pizarrones multimedia de 65" en los edificios D, P y W; se realizó pintado, repellado e impermeabilizante en 229 m² de muros de edificio Audiovisual; y el pintado de 206.32 m² en 10 rampas inclusivas en áreas comunes.

Acciones

1. Conservación y mantenimiento del material de biblioteca.
2. Mantenimiento a puerta de acceso de aluminio.
3. Mantenimiento a 5 m² de piso cerámico y zoclo en comedor de edificio Audiovisual.
4. Mantenimiento a sanitarios en área de impresiones, colocación de piso cerámico, salidas hidráulicas, sanitarias y eléctricas.
5. Mantenimiento a cuarto oscuro de fotografía, distribución de circuitos eléctricos, tablero nuevo, contactos, luminarias, tratamiento contra la humedad, repellado y pintura.
6. Mantenimiento a 41.14m² de 3 rampas de acceso para personas con discapacidad en los edificios F y G.

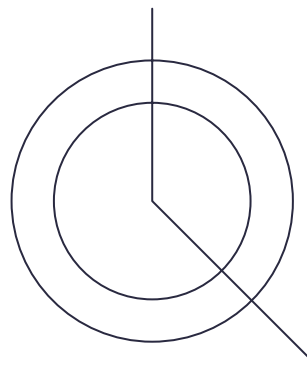
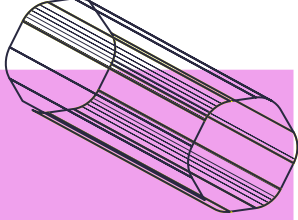

7. Mantenimiento a barras de lavabo en sanitarios con canal de acero inoxidable, en los edificios A, T, G, K y S.
8. Pintura epóxica a 455.33 m² de piso de laboratorio de cómputo en Edificio B.
9. Sustitución de 16 m de línea sanitaria.
10. Limpieza profunda de 582.62 m² de cancelería y herrería.
11. Instalación de protección para pizarrón multimedia de 65" en los edificios D, P y W, 10 piezas.
12. Instalación eléctrica y de datos para conexión de pantallas de 65" en los edificios D, P y W.
13. Pintura, repellido e impermeabilizante en 229 m² de muros de edificio Audiovisual.
14. Desplante de muro de mampostería con reja tubular, 6 metros lineales realizados en el Siladin.
15. Desmontaje y puerta nueva de acceso de Siladin, 1 pieza.
16. Pintado de 206.32 m² en 10 rampas inclusivas en áreas comunes.
17. Mantenimiento a 400 m² de membrana prefabricada en losa maciza del edificio PEC-1.
18. Mantenimiento a 9 m² de losa maciza y 11.20 m² de muro en edificio de Audiovisual.
19. Mantenimiento a 8 módulos de sanitarios con 16 barras de agarre.
20. Mantenimiento a un canalón y aplicación de 597 m² de impermeabilizante de sala de cine, sala de conferencias y tele-aula Serafín Benítez en edificio Audiovisual.

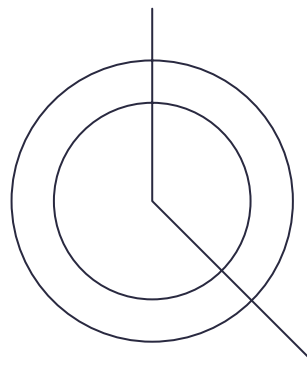
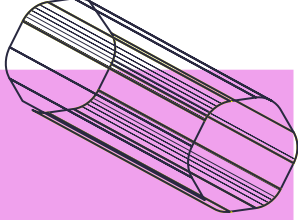

21. Suministro y colocación de 27 m² de piso cerámico en área de firmas en edificio A.
22. Colocación de lavabo de acero inoxidable en sanitarios de alumnas edificio A, 1 pieza.
23. Mantenimiento de firme de concreto en acceso de estacionamiento superior 30.44 m².

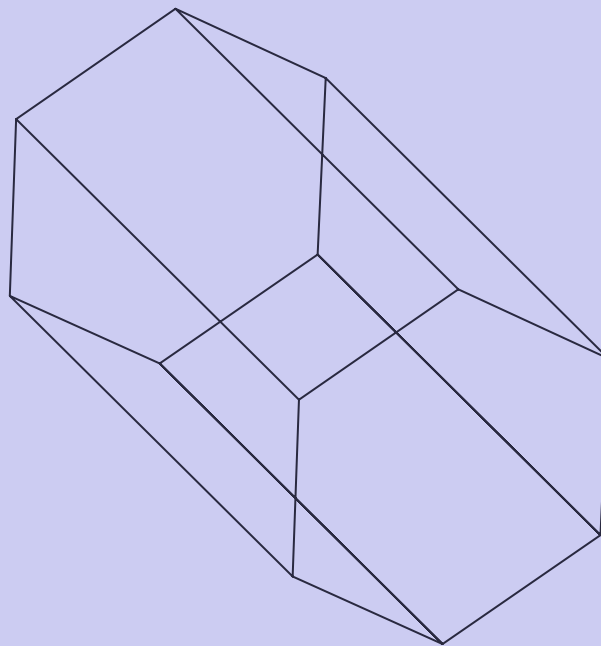

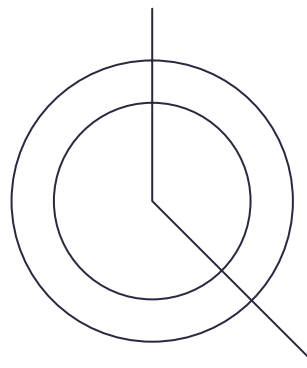
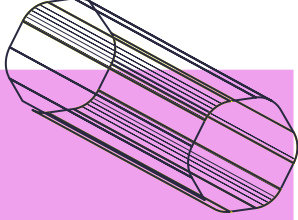

1. Conservación y mantenimiento del material de biblioteca.

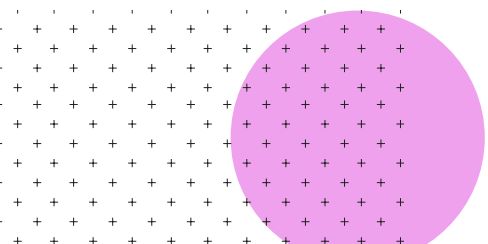

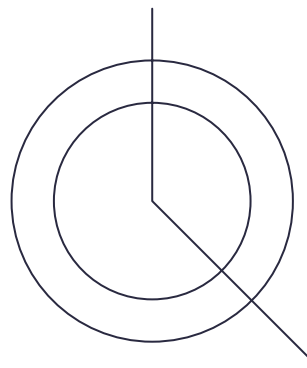
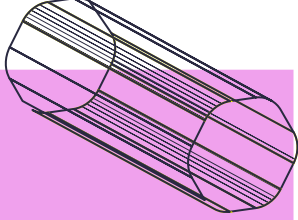

2. Mantenimiento a puerta de acceso de aluminio.

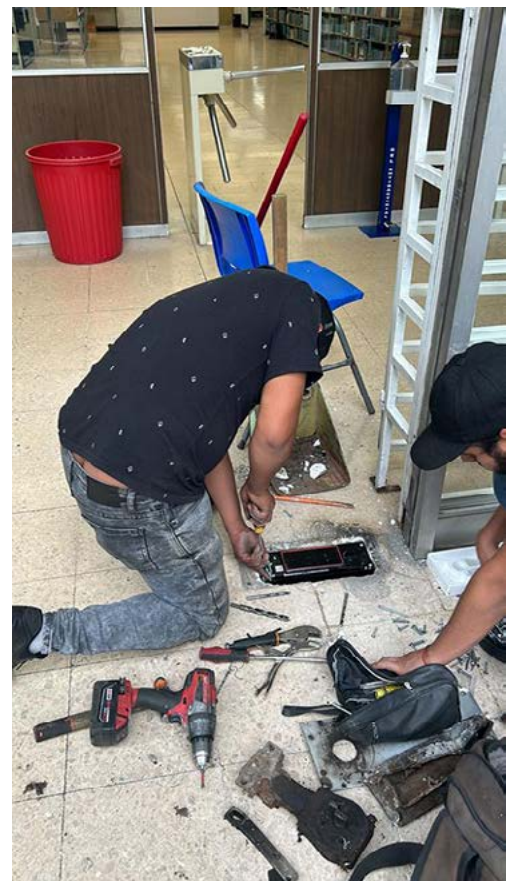

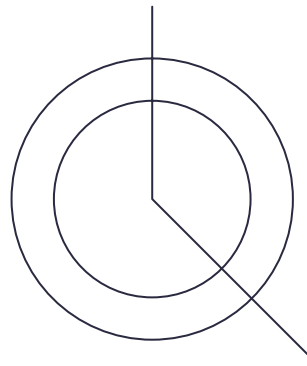
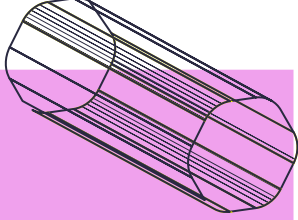

3. Mantenimiento a 5 m² de piso cerámico y zoclo en comedor de edificio Audiovisual.



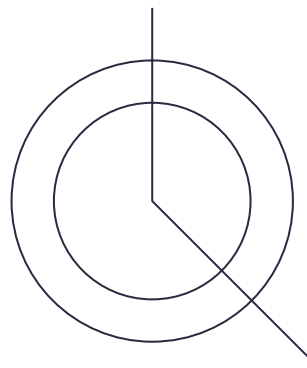
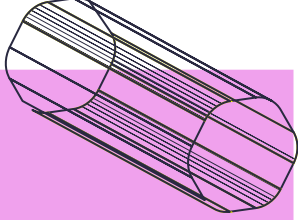

4. Mantenimiento a sanitarios en área de impresiones, colocación de piso cerámico, salidas hidráulicas, sanitarias y eléctricas.



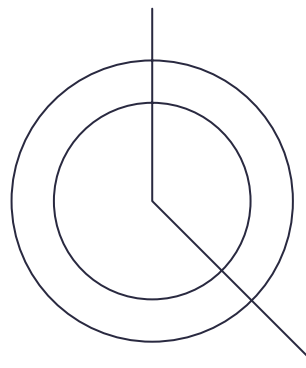
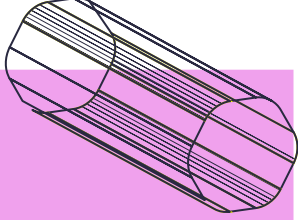

5. Mantenimiento a cuarto oscuro de fotografía, distribución de circuitos eléctricos, tablero nuevo, contactos, luminarias, tratamiento contra la humedad, repellado y pintura.

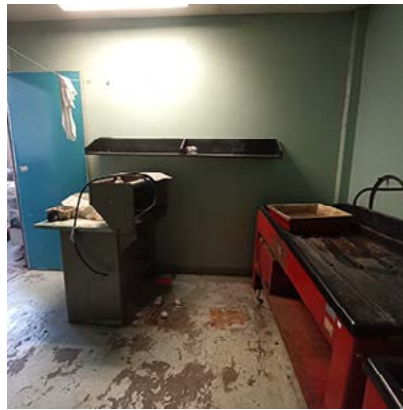
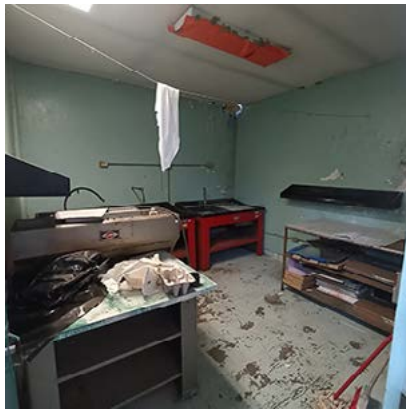

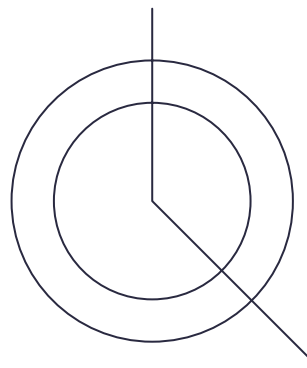
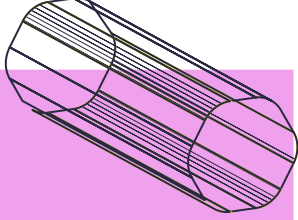

6. Mantenimiento a 41.14m² de 3 rampas de acceso para personas con discapacidad en los edificios F y G.



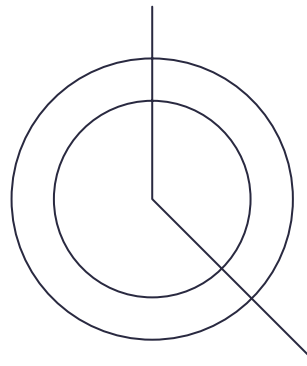
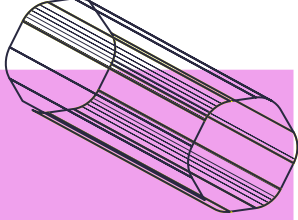

7. Mantenimiento a 8 barras de lavabo en sanitarios con canal de acero inoxidable, en los edificios A, T, G, K y S.



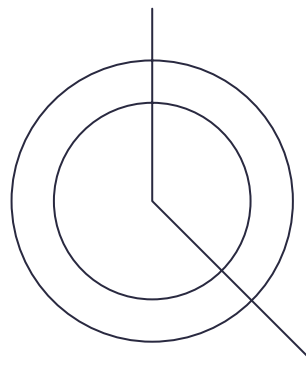
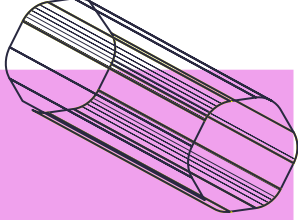

8. Pintura epóxica a 455.33 m² de piso de Laboratorio de Cómputo, en edificio B.

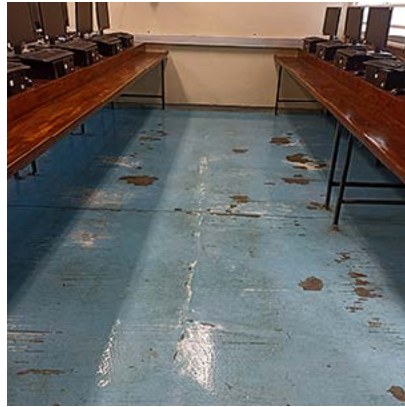
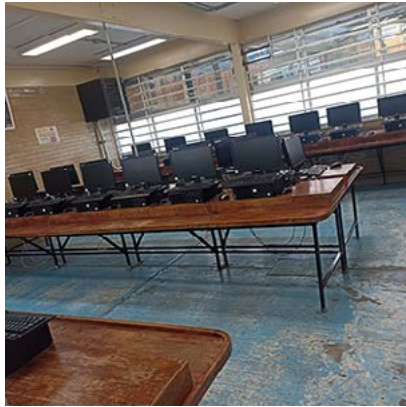

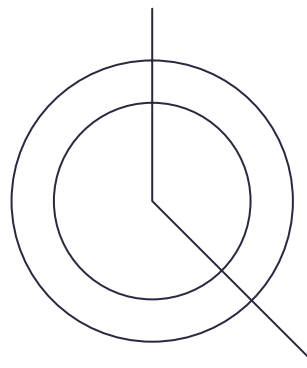
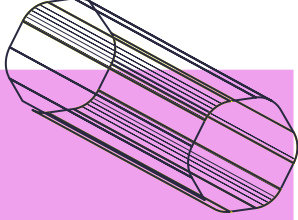

9. Sustitución de 16 m de línea sanitaria.



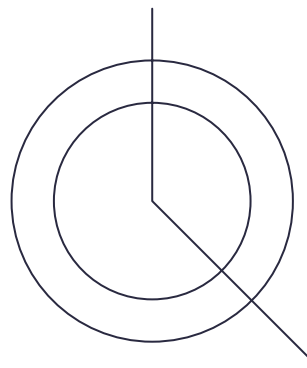
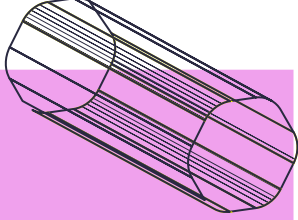

10. Limpieza profunda a 582.62 m² de cancelería y herrería.

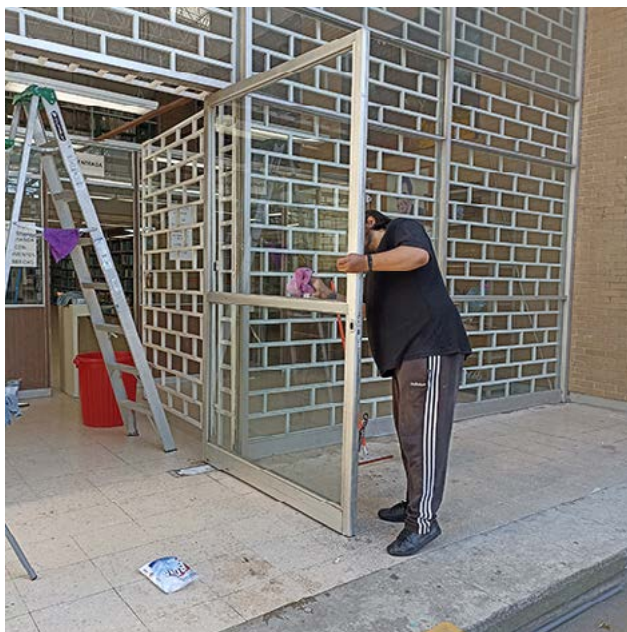

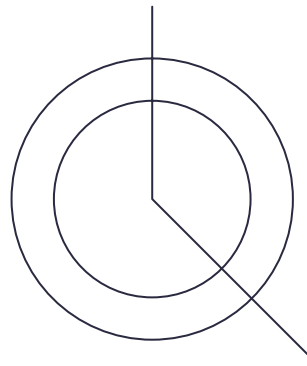
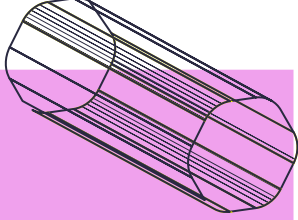

11. Instalación de protección para pizarrón multimedia de 65" en los edificios D, P y W, 10 piezas.



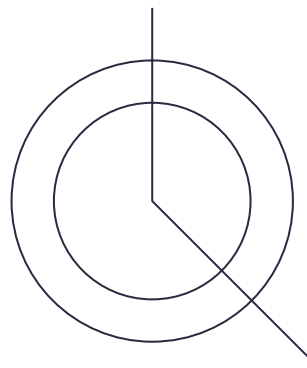
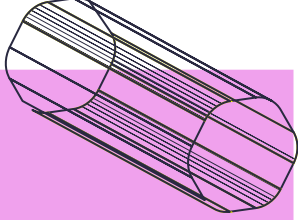

12. Instalación eléctrica y de datos para conexión de pantallas de 65" en los edificios D, P y W.



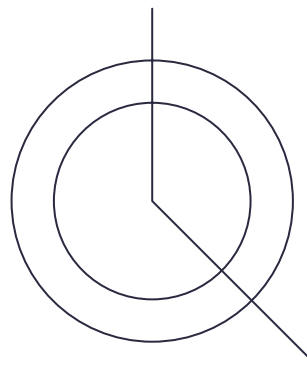
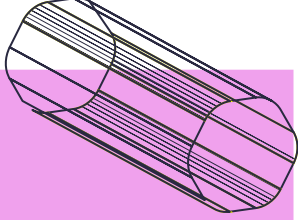

13. Pintura, repellado e impermeabilización en 229 m² de muros de edificio Audiovisual.



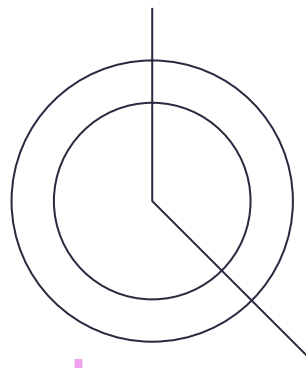
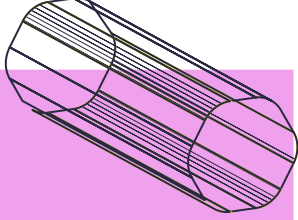

14. Desplante de muro de mampostería con reja tubular, 6 m lineales realizados en Siladin.

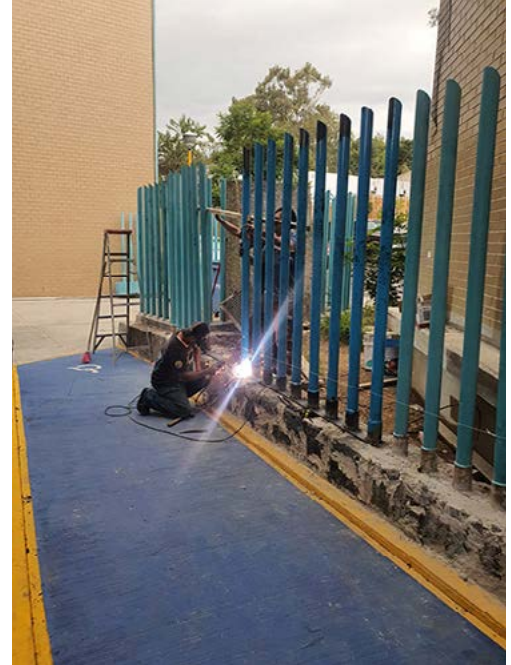

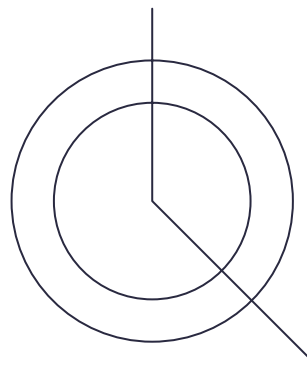
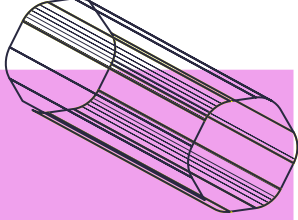

15. Desmontaje y puerta nueva de acceso del Siladin, 1 pieza.



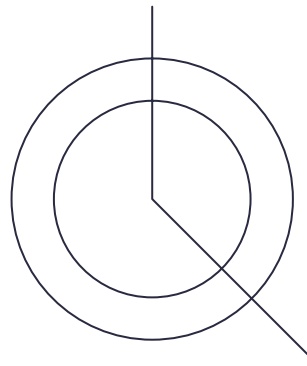
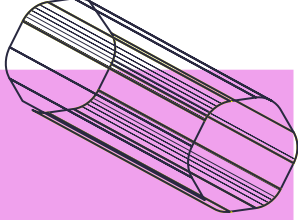

16. Pintado de 206.32 m² en 10 rampas inclusivas en áreas comunes.



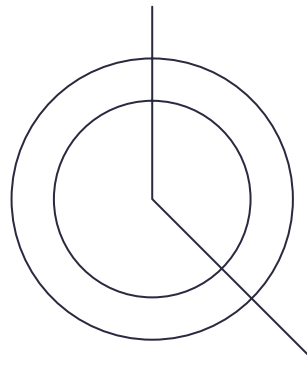
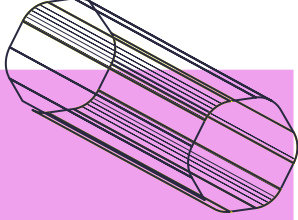

17. Mantenimiento a 400 m² de membrana prefabricada en losa maciza del edificio PEC-1.



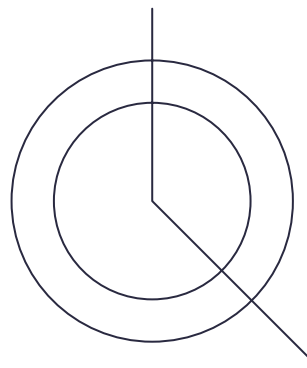
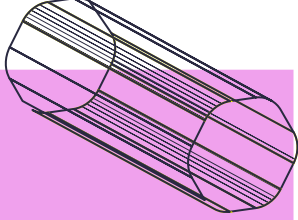

18. Mantenimiento a 9 m² de losa maciza y 11.20 m² de muro en edificio de Audiovisual.



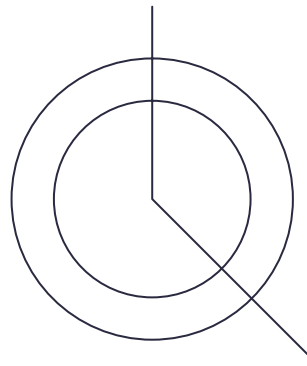
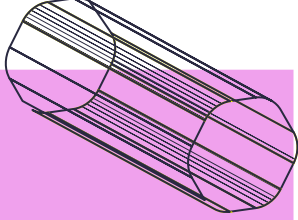

19. Mantenimiento a 8 módulos de sanitarios con 16 barras de agarre.



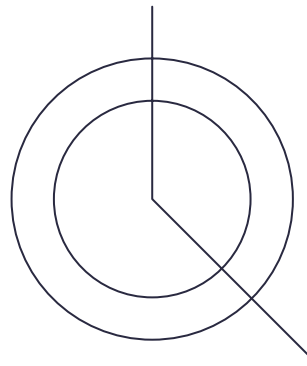
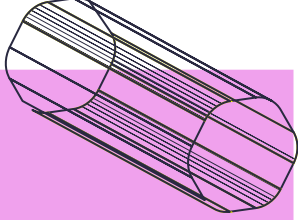

20. Mantenimiento a un canalón y aplicación de 597 m² impermeabilizante de sala de cine, sala de conferencias y tele-aula Serafín Benítez en edificio de Audiovisual.

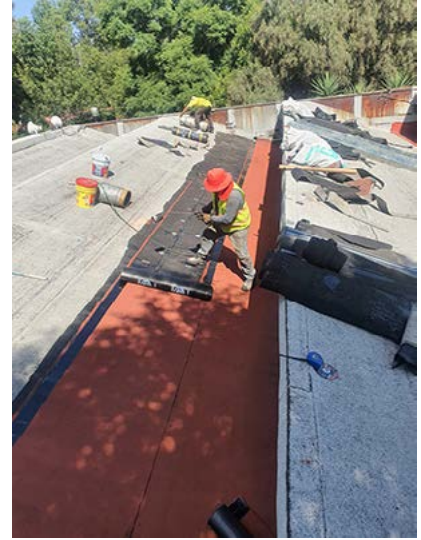
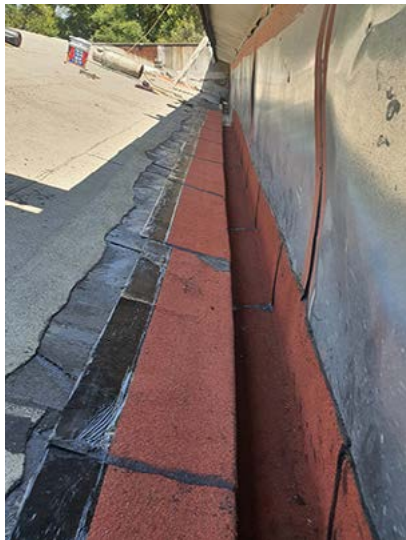

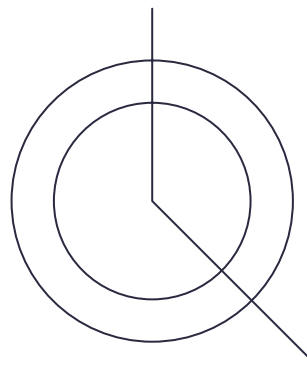
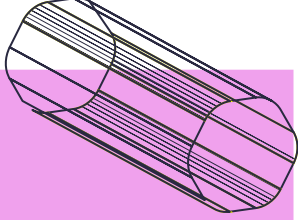

21. Suministro y colocación de 27 m² de piso cerámico en área de firmas en edificio A.



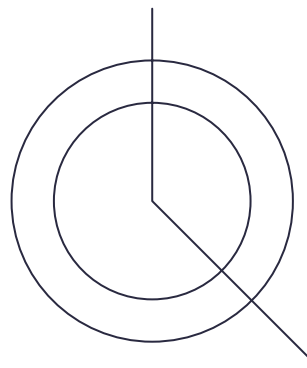
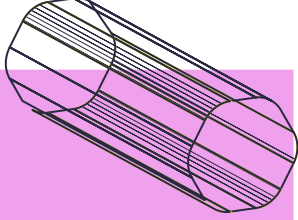

22. Colocación de lavabo de acero inoxidable en sanitarios de alumnas edificio A, 1 pieza.

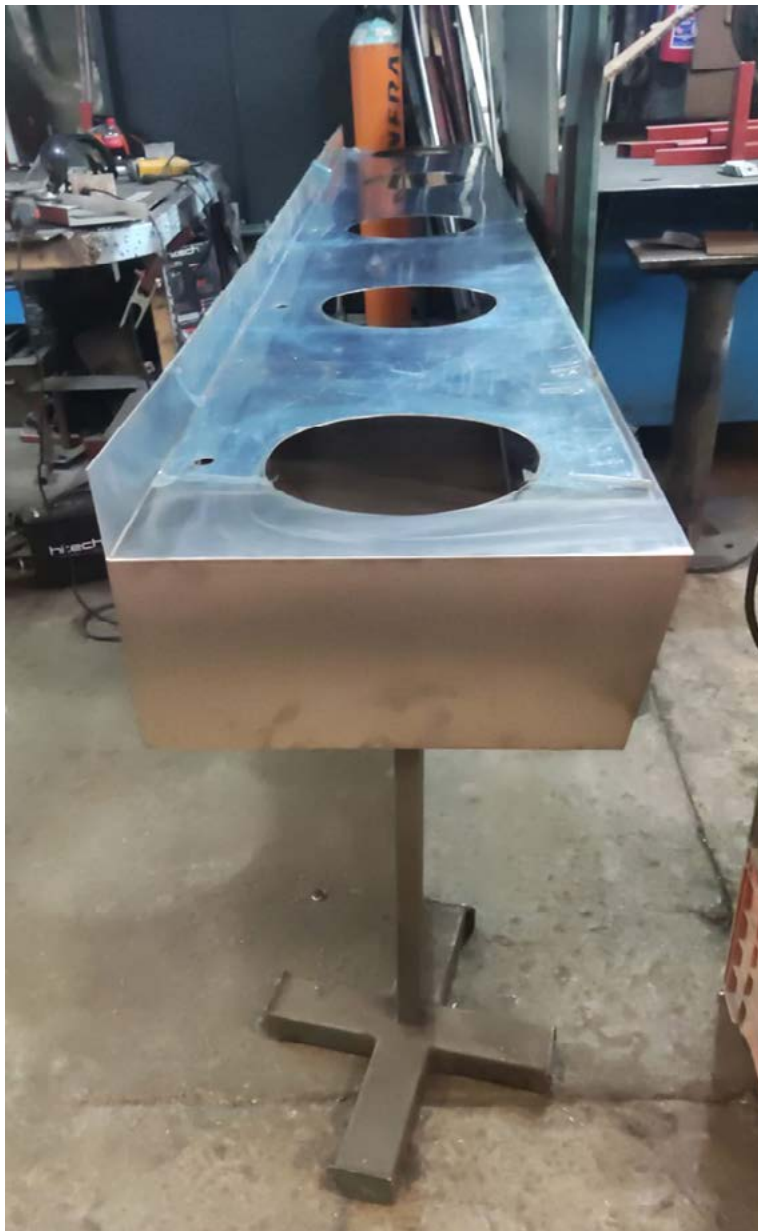

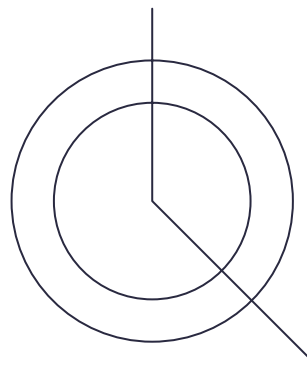
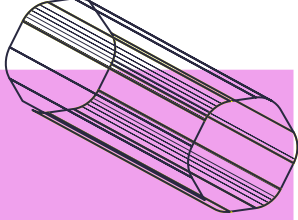

23. Mantenimiento de firme de concreto en acceso de estacionamiento superior 30.44 m².



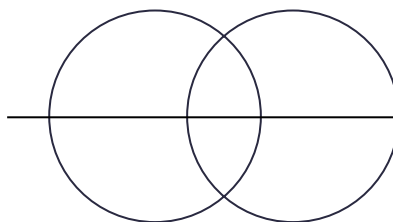
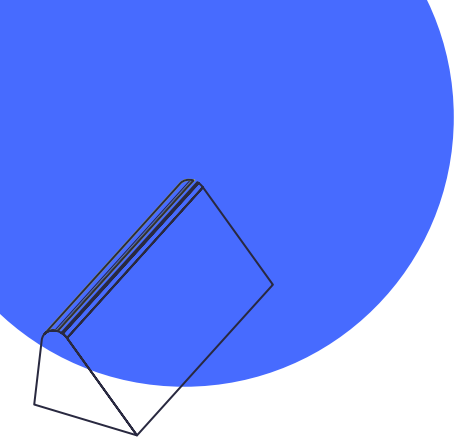

PLANTEL VALLEJO

En el plantel Vallejo se realizó la limpieza de azoteas de distintos edificios, núcleos sanitarios, anaqueles y bodega del Departamento de Bienes y Suministros. También se colocaron 15 reflectores en andadores, pasillos y explanadas; se repararon y dio mantenimiento a alimentadores eléctricos; se modificó la línea hidráulica y sanitaria con cambio de 20 muebles sanitarios. Además, se realizó la poda y tala de 50 árboles y la poda de 100 m² de pasto. Y se continúa con el avance de la construcción del edificio de Laboratorios.

Acciones:

1. Poda de 100 m² de pasto.
2. Limpieza de 600 m² de azoteas: Biblioteca, Gimnasio, CREPA, Siladin, techumbre de cafeterías, Velaria de la explanada principal y cubierta de edificio de Escolares.
3. Limpieza de 12 núcleos sanitarios.
4. Limpieza de 120 m² de anaqueles y bodega del Departamento de Bienes y Suministros.
5. Poda y tala de 50 árboles.

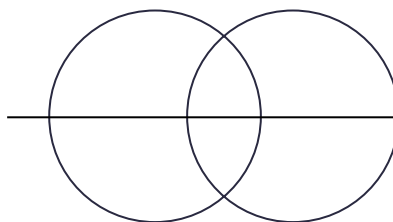
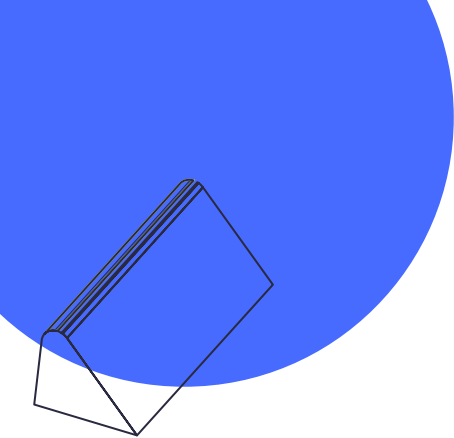

6. Colocación de 15 reflectores en andadores, pasillos y explanadas.
7. Modificación de línea hidráulica y sanitaria, con cambio de muebles sanitarios, 20 piezas.
8. Fabricación de trayectoria para alimentadores eléctricos, incluye reparación de registros de 130 mm.
9. Aplicación de pintura a 1,900 m² de fachadas de edificios I, L, CREPA y M.
10. Mantenimiento preventivo a equipos hidroneumáticos, equipo de bombeo y vacío en Siladin, 18 servicios.
11. Mantenimiento preventivo a subestación eléctrica, una subestación y 3 transformadores secos.
12. Colocación de muebles sanitarios, incluye: modificación de red hidráulica y sanitaria; desmantelamiento y demoliciones, 20 piezas.
13. Fabricación de ventilas tipo Louver de 20 mm.
14. Reparación de alimentadores eléctricos del edificio N; mantenimiento de alimentadores de los edificios K y L. Incluye: mantenimiento a tableros eléctricos de los edificios N, K y L, realizados 600 mm.
15. Construcción del edificio de Laboratorios en el plantel Vallejo.

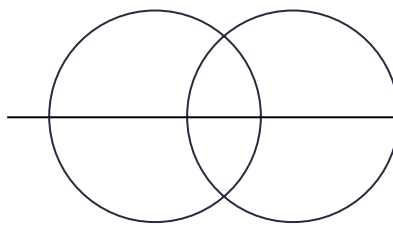
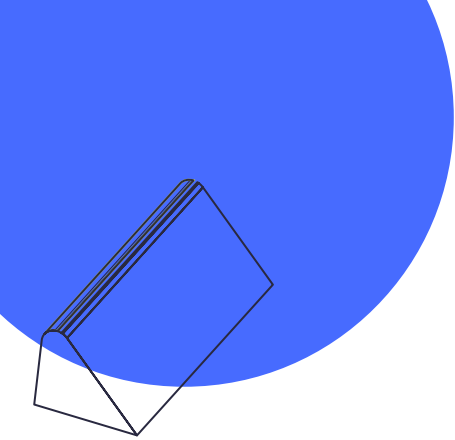

1. Poda de 100 m² de pasto.

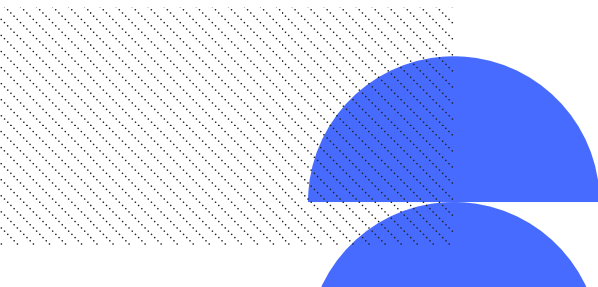

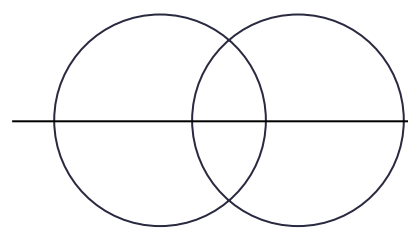
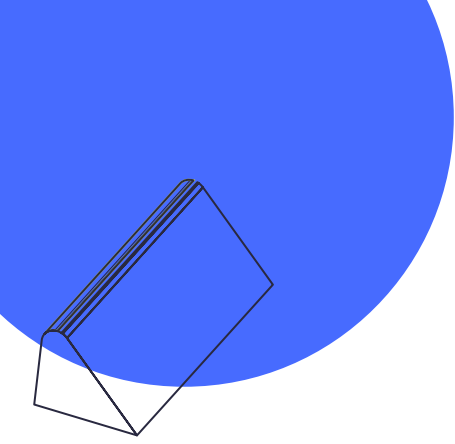

**2. Limpieza de 600 m² de azoteas:
Biblioteca, Gimnasio, CREPA, Siladin,
techumbre de cafeterías, Velaria de
la explanada principal y cubierta
de edificio de Escolares.**



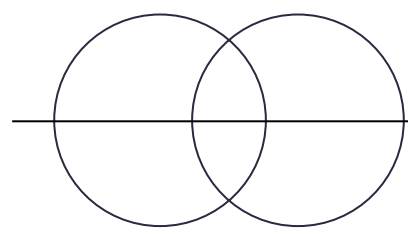
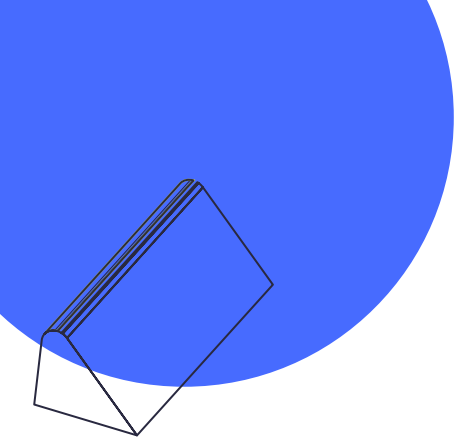

3. Limpieza de 12 núcleos sanitarios.

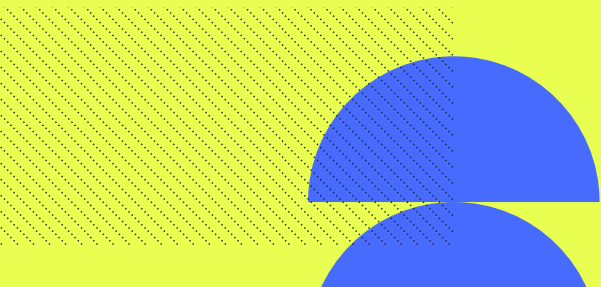
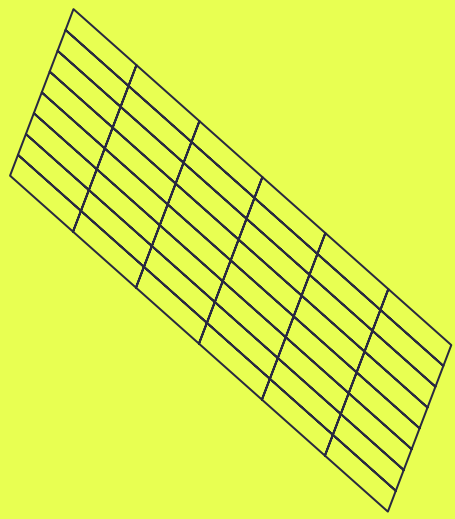

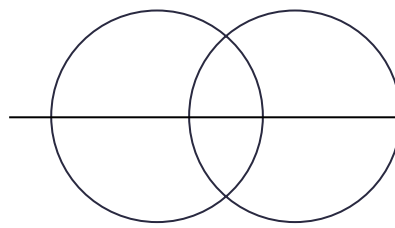
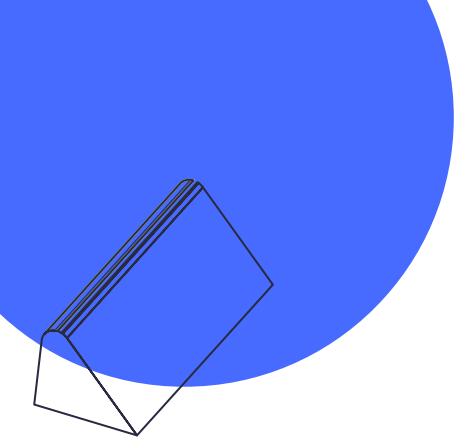

4. Limpieza de 120 m² de anaqueles y bodega del Departamento de Bienes y Suministros.

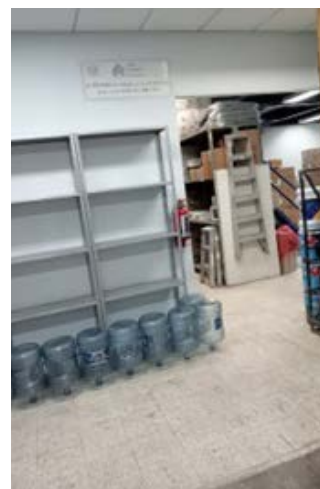

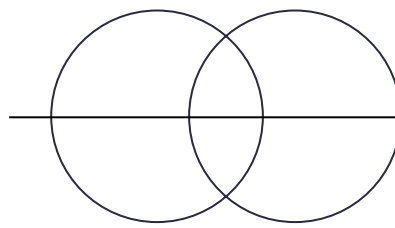
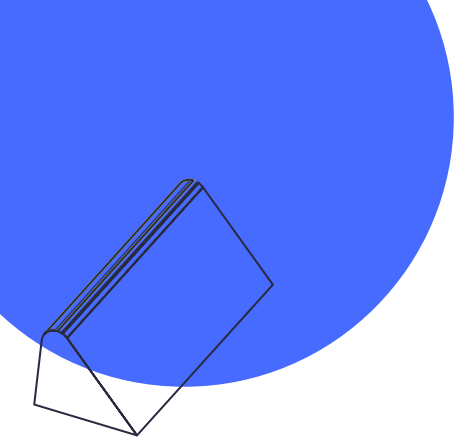

5. Poda y tala de 50 árboles.



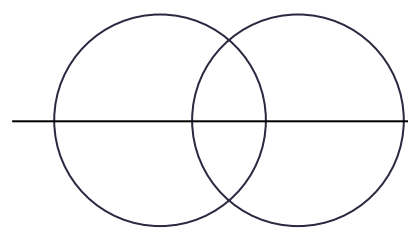
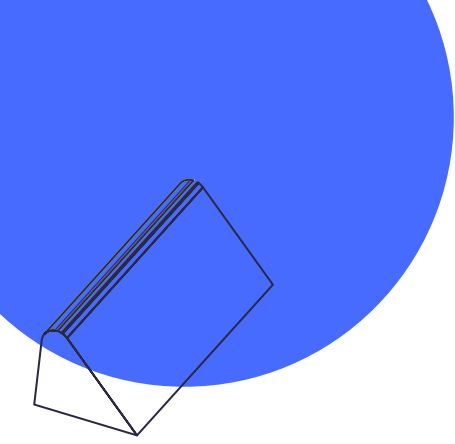

6. Colocación de 15 reflectores en andadores, pasillos y explanadas.

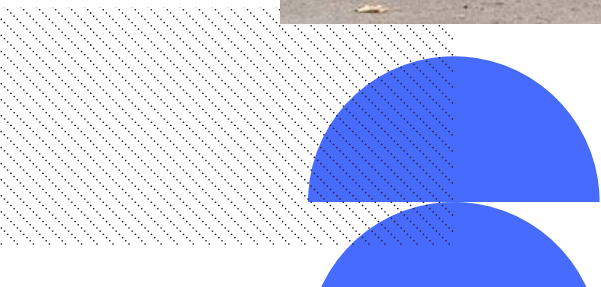

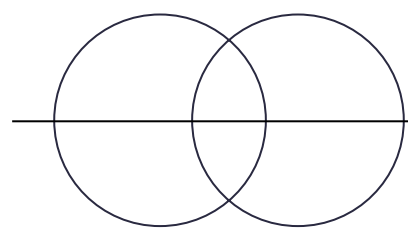
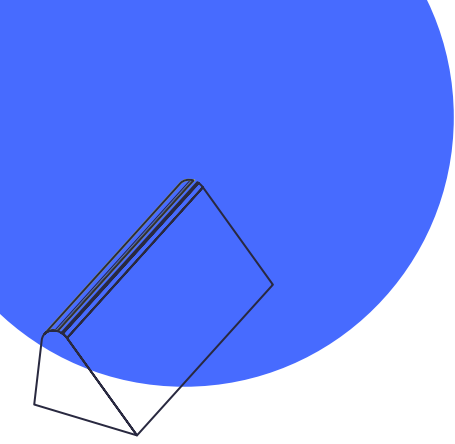

7. Modificación de línea hidráulica y sanitaria, con cambio de muebles sanitarios, 20 piezas.



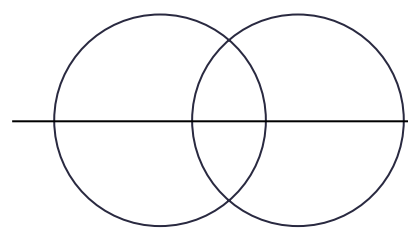
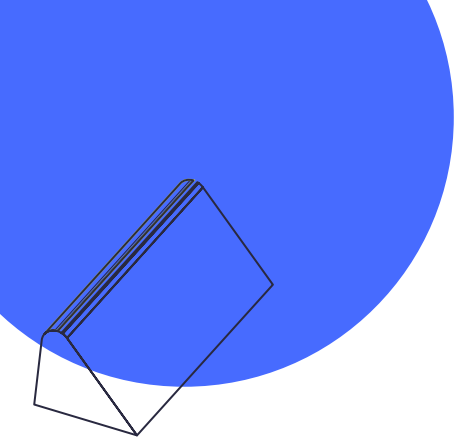

8. Fabricación de trayectoria para alimentadores eléctricos, incluye reparación de registros de 130 mm.

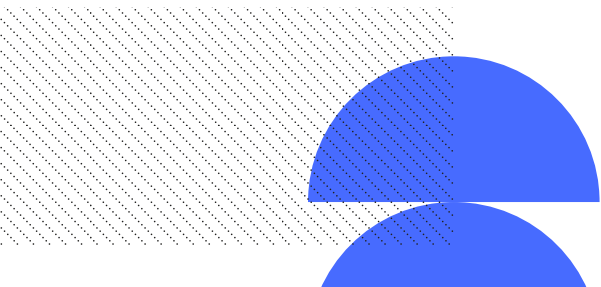

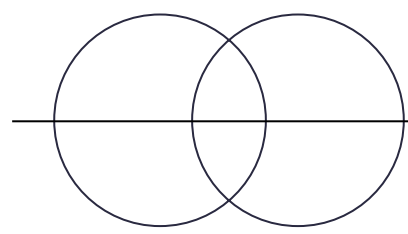
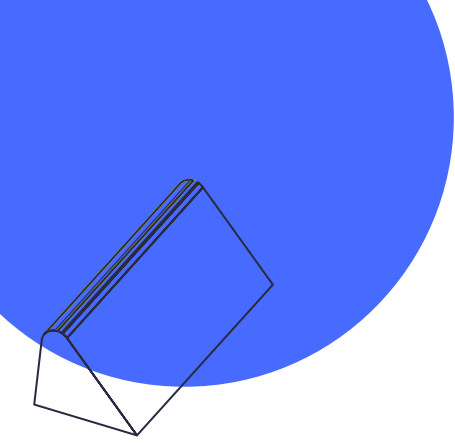

9. Aplicación de pintura a 1,900 m² de fachadas de edificios I, L, CREPA y M.

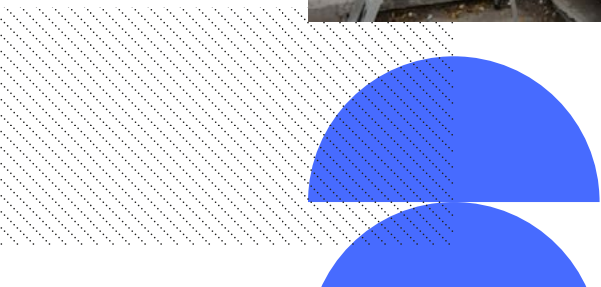

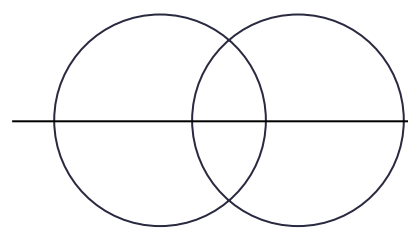
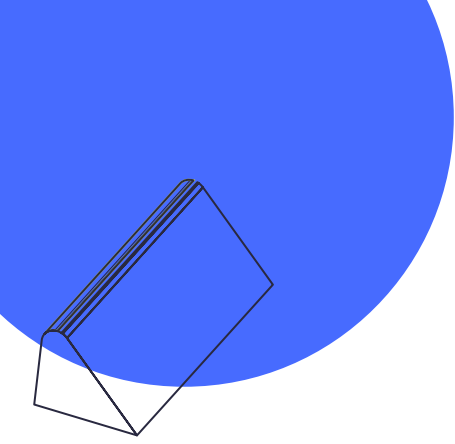

10. Mantenimiento preventivo a equipos hidroneumáticos, equipo de bombeo y vacío en Siladin, 18 servicios.

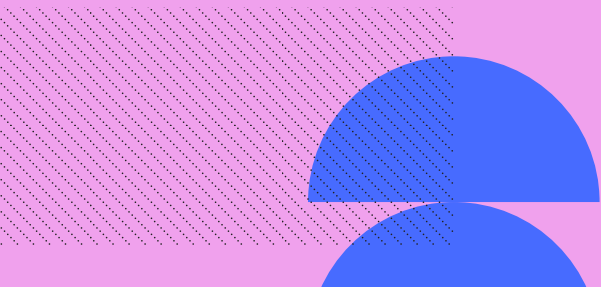

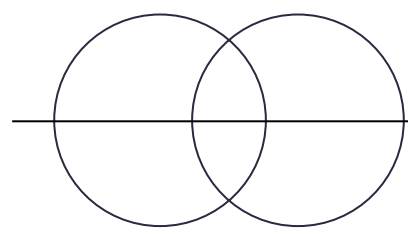
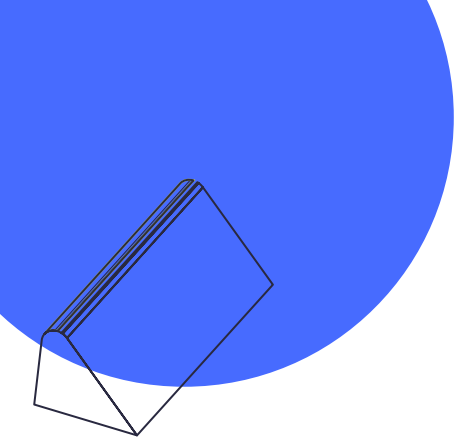

11. Mantenimiento preventivo a subestación eléctrica, una subestación y 3 transformadores secos.



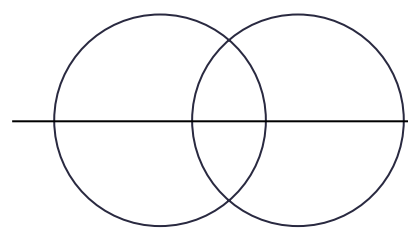
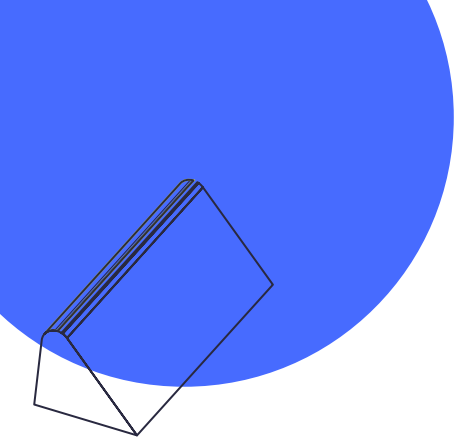

13. Fabricación de ventilas tipo Louver de 20 mm.

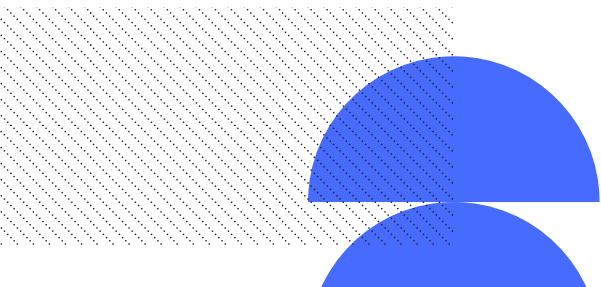

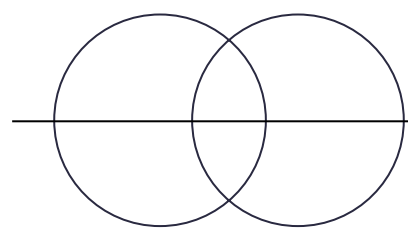
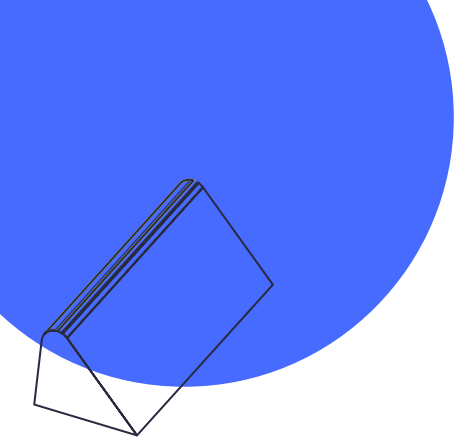

14. Reparación de alimentadores eléctricos del edificio N; mantenimiento de alimentadores de los edificios K y L. Mantenimiento a tableros eléctricos de los edificios N, K y L, realizados 600 mm.



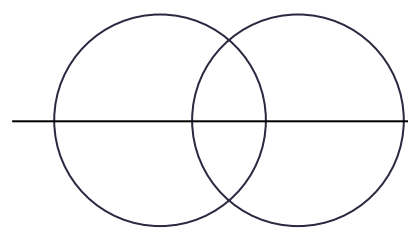
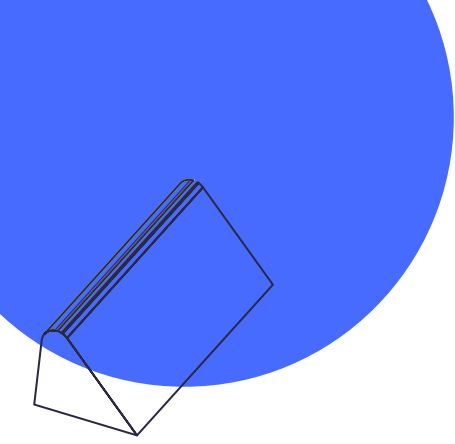

15. Construcción del edificio de Laboratorios en el plantel Vallejo.

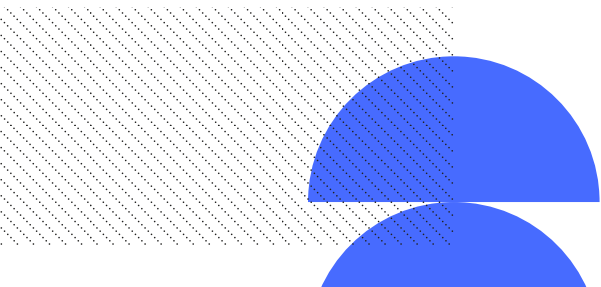

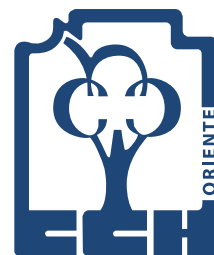

PLANTEL ORIENTE

En el plantel Oriente se realizó la limpieza de la Biblioteca, de la cisterna de la Dirección; asimismo, se colocaron 333 m² de piso en Dirección y 222 m² de piso de laboratorio de edificio L, se realizó cambio de pendiente e impermeabilización de losa y cambio de canalones de lámina en edificio de Mantenimiento. Además, se construyeron 70 m² del andador para estudiantes.

Acciones:

1. Colocación de 333 m² de piso en Dirección.
2. Cambio de pendiente e impermeabilizante de 150 m² de losa.
3. Cambio de canalones de lámina en edificio de Mantenimiento, 8 piezas de 28.36 m².
4. Colocación de 222 m² de piso de laboratorio de edificio L.
5. Rehabilitación de 328 m² de Taller de Mantenimiento.
6. Limpieza profunda de 1,553 m² de Biblioteca.
7. Limpieza de 1,281 m² de cisterna.
8. Pintura perimetral en 1,611 m².
9. Construcción de 70 m² del andador para estudiantes.
10. Limpieza y aplicación de pintura en 617 m² de Dirección.

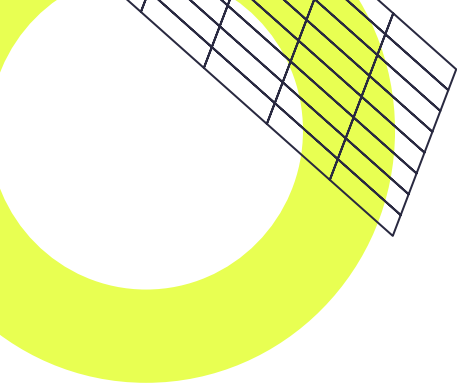

1. Colocación de 333 m² de piso en Dirección.

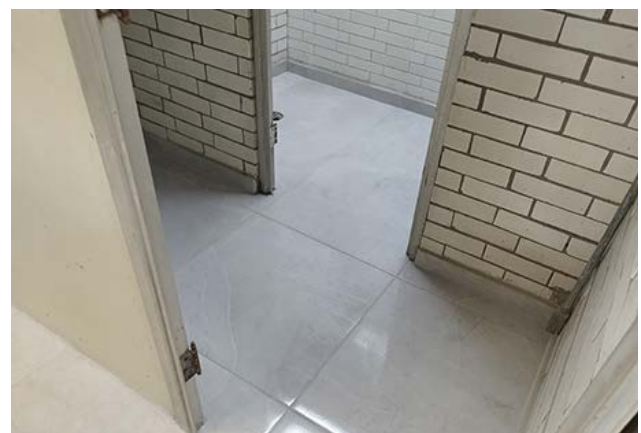
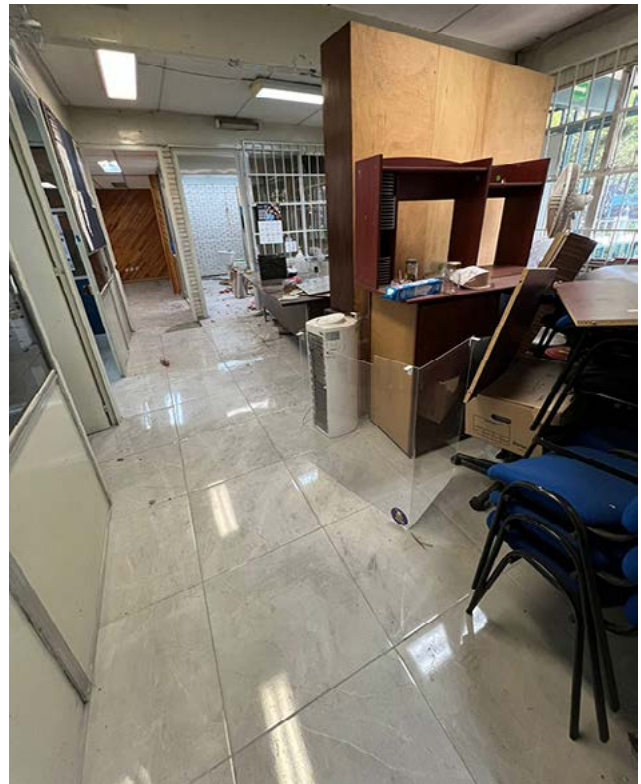
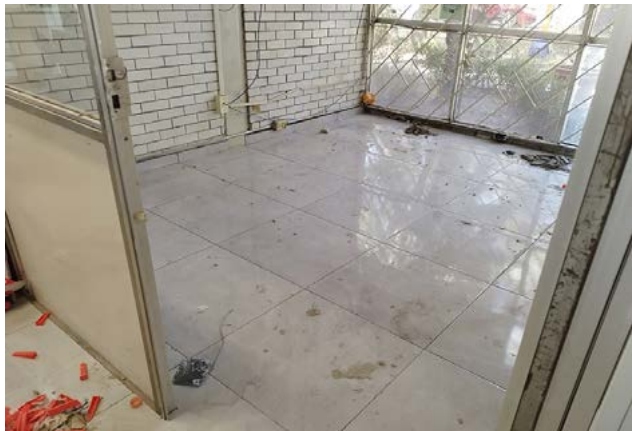

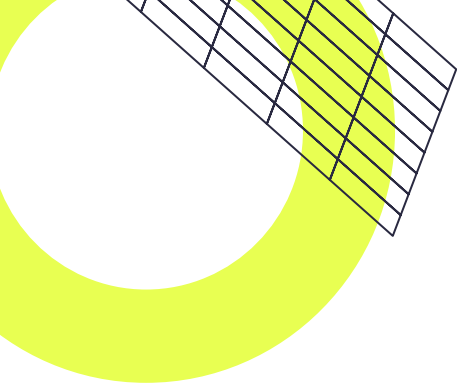

2. Cambio de pendiente e impermeabilizante de 150 m² de losa.



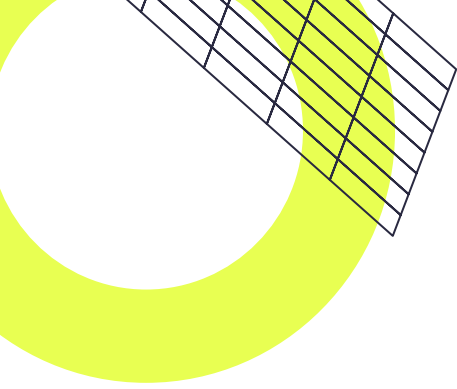

3. Cambio de canalones de lámina en edificio de Mantenimiento, 8 piezas de 28.36 m².

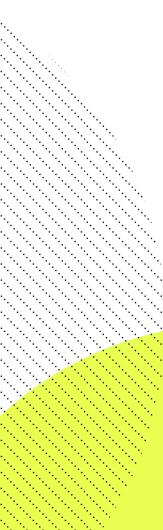
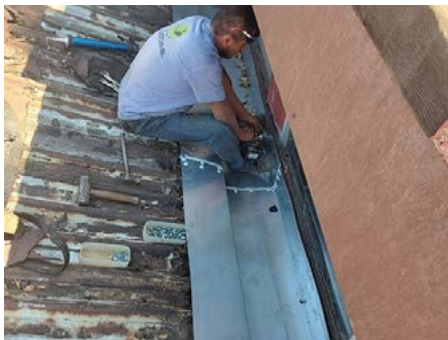

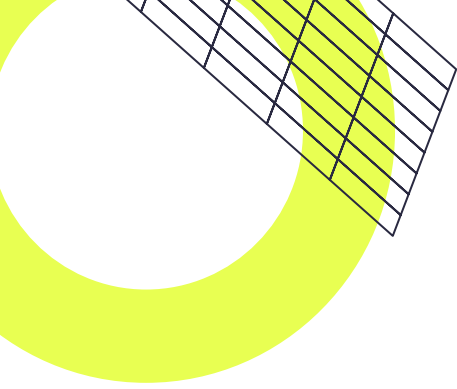

4. Colocación de 222 m² de piso de laboratorio de edificio L.

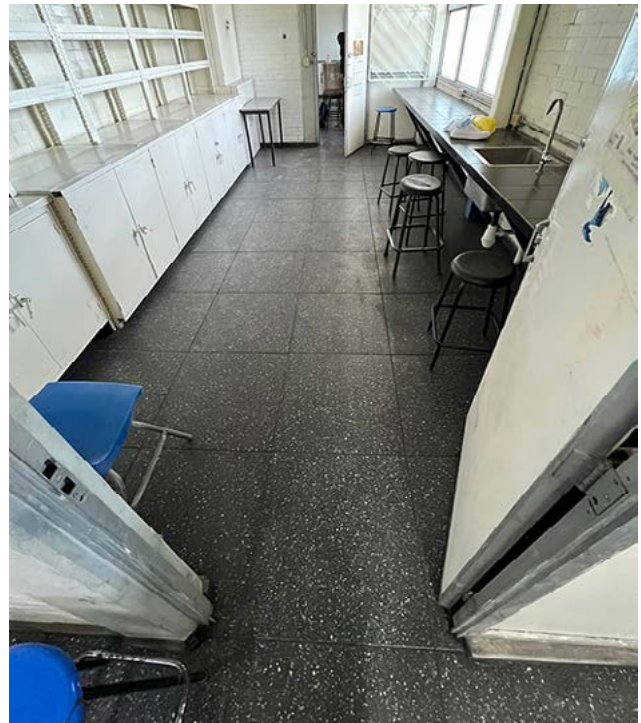

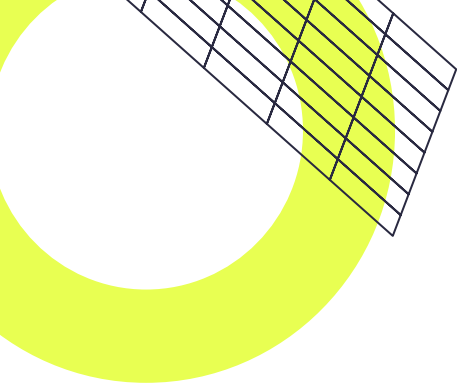

5. Rehabilitación de 328 m² de taller de mantenimiento.

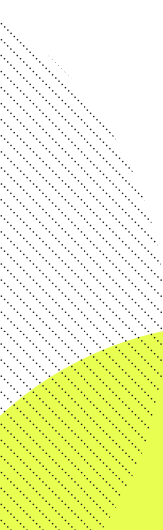

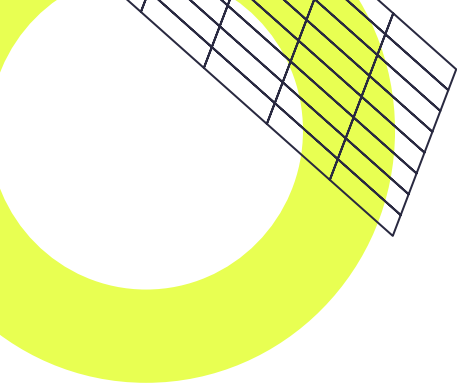

6. Limpieza profunda de 1,553 m² de Biblioteca.



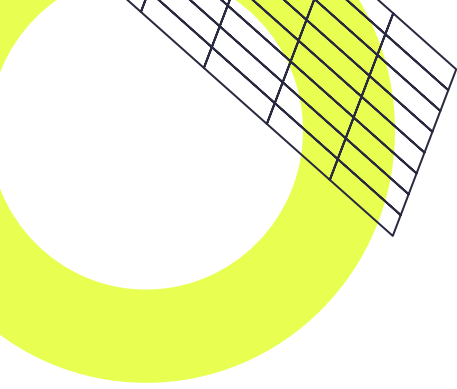

7. Limpieza de 1,281 m² de cisterna.



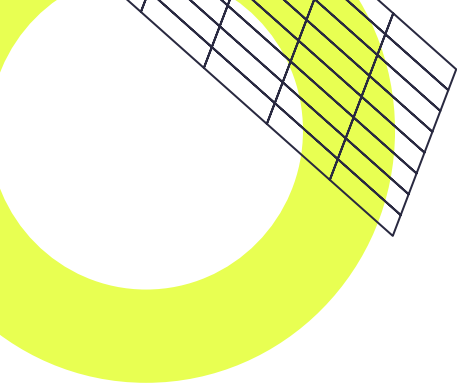

8. Pintura perimetral en 1,611 m².



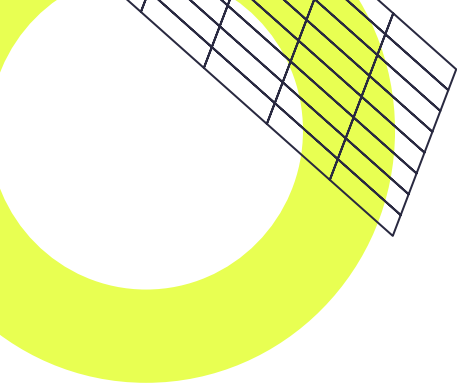

9. Construcción de 70 m² de andador para estudiantes.



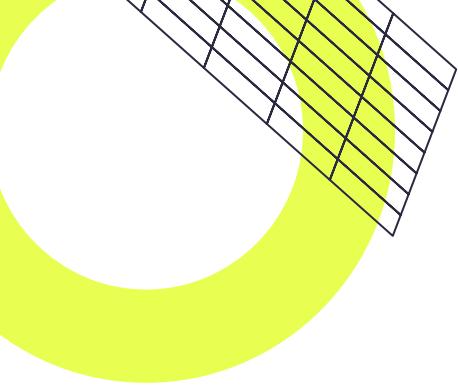

10. Limpieza y aplicación de pintura en 617 m² de Dirección.



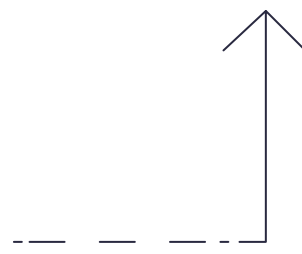
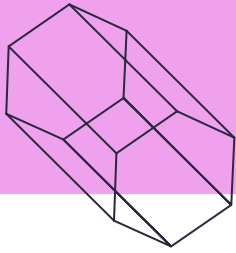

PLANTEL SUR

En el plantel Sur se realizó la colocación e instalación de 15 reflectores, 10 postes, lavabos, cerrojos en ventanas corredizas y de cristales. También se hizo impermeabilización del área de impresiones, limpieza y remoción de grafitis y fabricación de protecciones de herrería, de reja y de pantallas.

Acciones:

1. Impermeabilización de área de impresiones, 54 m lineales.
2. Fabricación y colocación de protecciones de herrería en Dirección, 27 piezas.
3. Poda, deshierbe y desrame en 3,200 m² del camino verde.
4. Tala de 5 árboles secos en diferentes áreas del plantel.
5. Colocación e instalación de 15 reflectores en diferentes áreas del plantel.
6. Colocación e instalación de 10 postes en diferentes áreas del plantel.
7. Reparación de fugas en núcleos sanitarios de escolares, realizado en 2 m².



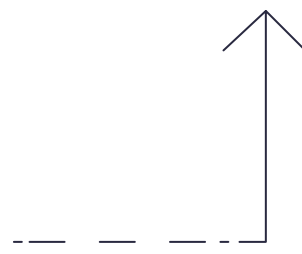
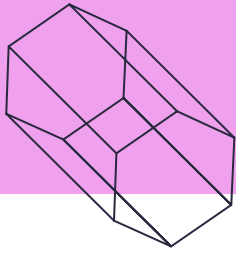

8. Colocación de cerrojos en ventanas corredizas del edificio G, 90 piezas.
9. Limpieza y remoción de grafitis edificio de Dirección, realizados en 390 m².
10. Limpieza y remoción de grafitis Siladin 1 y 2, realizados en 500 m².
11. Reacondicionamiento de 120 m² de jardín entre edificios G y H.
12. Lavado de 450 m³ cisterna.
13. Fabricación y colocación de 24 m² de reja en edificio G.
14. Fabricación de muebles para pantallas edificio Z, 7 piezas.
15. Colocación e instalación de lavabos en edificios LL y Dirección, 2 piezas.
16. Aplicación de pintura en 3,000 m² en edificios B, C, O, R y S.
17. Colocación de cristales en edificios de Siladin y Dirección, 150 piezas.
18. Desazolve de línea de drenaje, 7 fosas.

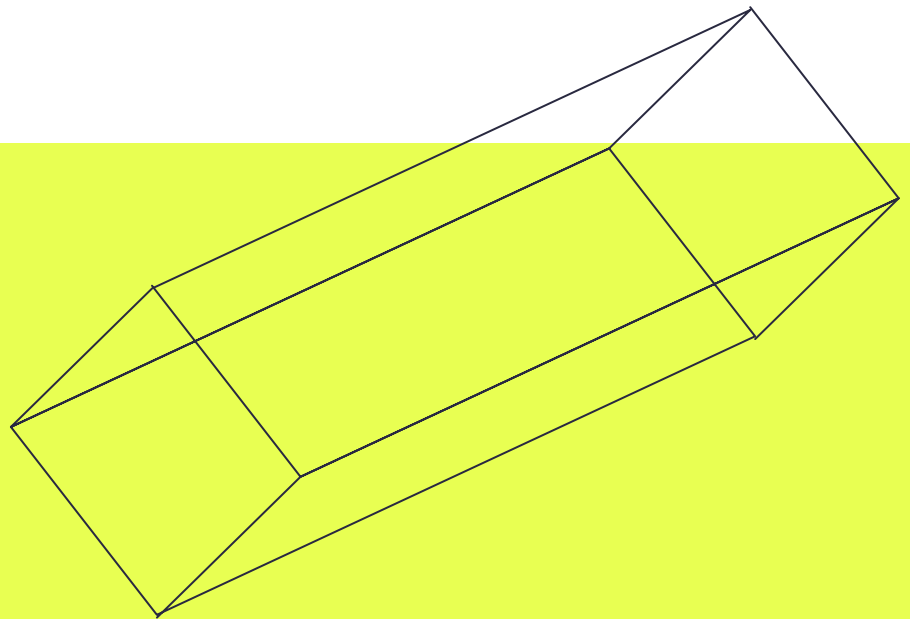

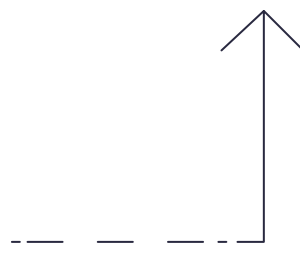
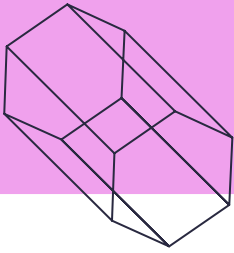

1. Impermeabilización área de impresiones, 54 ml.



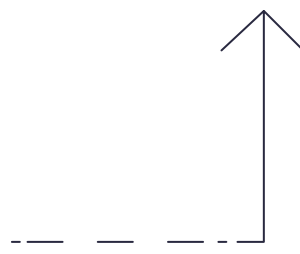
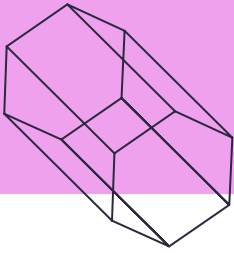

2. Fabricación y colocación de protecciones de herrería en Dirección, 27 piezas.



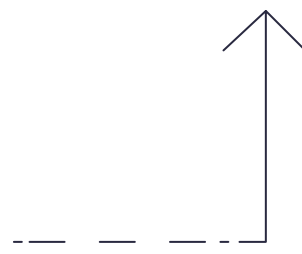
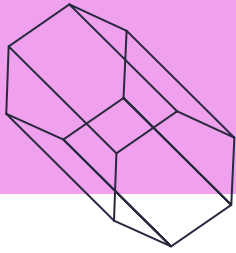

3. Poda, deshierbe y desrame en 3,200 m² del camino verde.



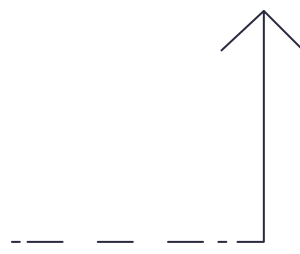
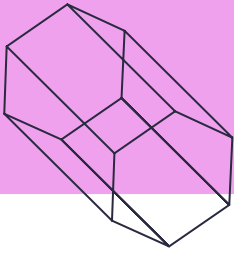

4. Tala de 5 árboles secos en diferentes áreas del plantel.



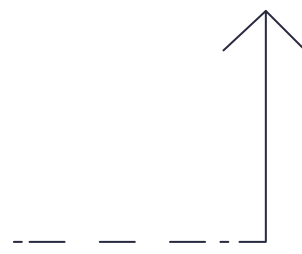
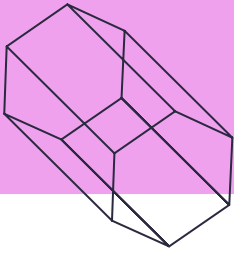

5. Colocación e instalación de 15 reflectores en diferentes áreas del plantel.

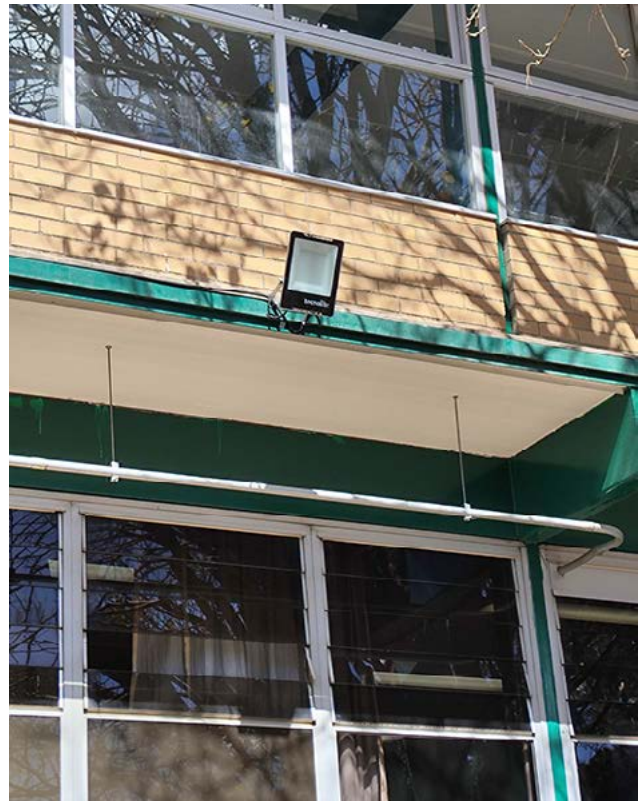
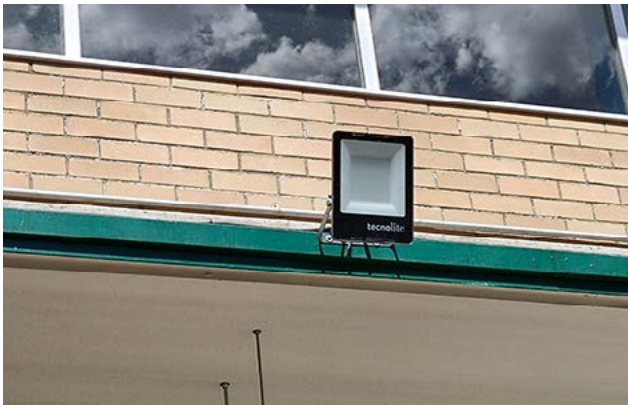

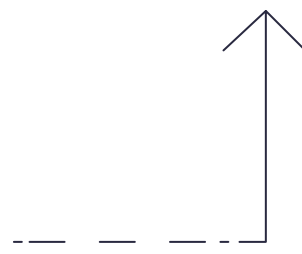
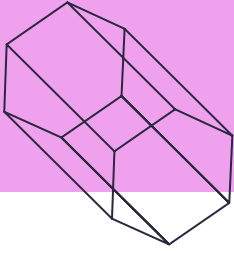

6. Colocación e instalación de 10 postes en diferentes áreas del plantel.



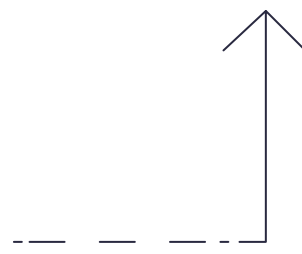
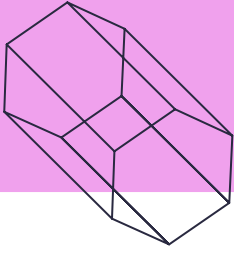

7. Reparación de fugas en núcleos sanitarios de escolares, realizado en 2 m².



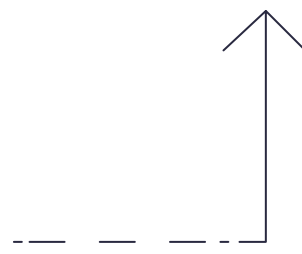
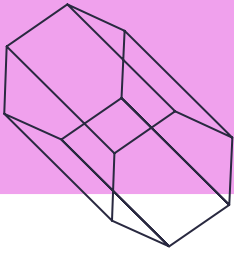

8. Colocación de cerrojos en ventanas corredizas del edificio G, 90 piezas.



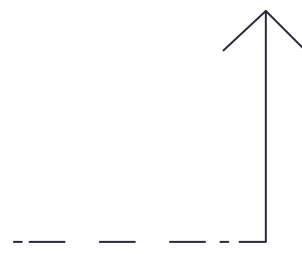
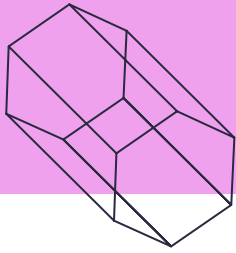

9. Limpieza y remoción de grafitis edificio de Dirección, realizados en 390 m².



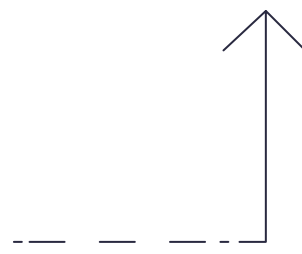
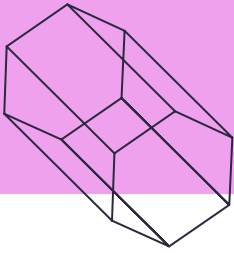

10. Limpieza y remoción de grafitis Siladin 1 y 2, realizados en 500 m².



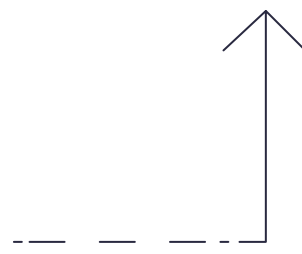
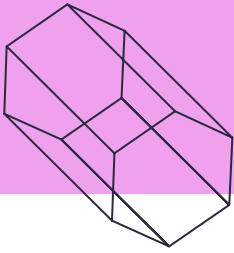

11. Reacondicionamiento de 120 m² de jardín entre edificios G y H.



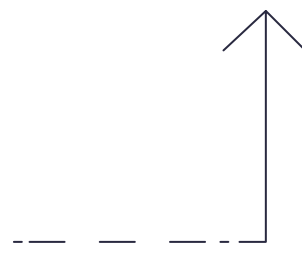
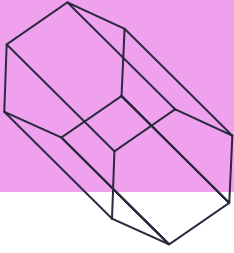

12. Lavado de 450 m³ cisterna.



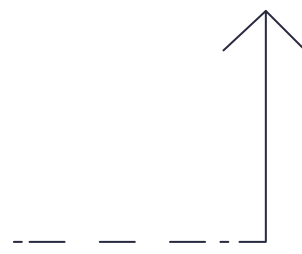
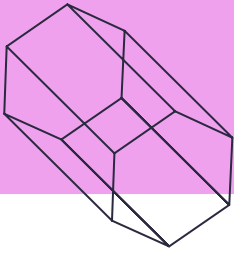

13. Fabricación y colocación de 24 m² de reja en edificio G.



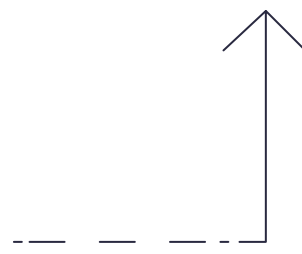
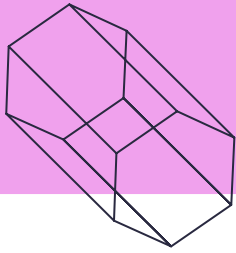

14. Fabricación de muebles para pantallas edificio Z, 7 piezas.



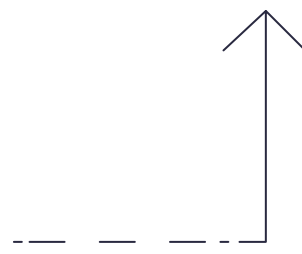
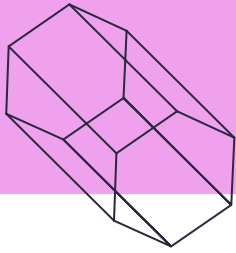

15. Colocación e instalación de lavabos en edificios LL y Dirección, 2 piezas.



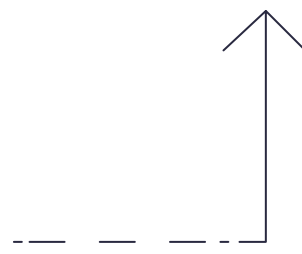
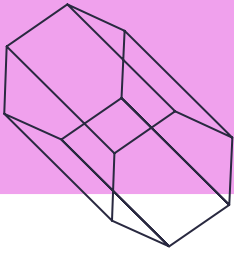

16. Aplicación de pintura en 3,000 m² en edificios B, C, O, R y S.

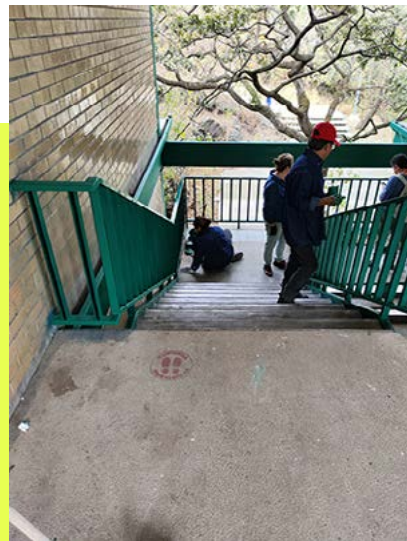

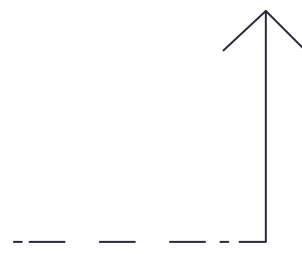
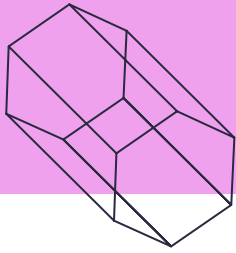

17. Colocación de cristales en edificios de Siladin y Dirección, 150 piezas.



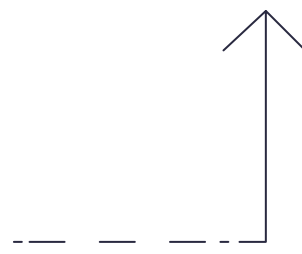
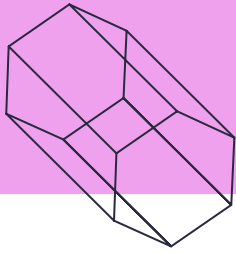

18. Desazolve de línea de drenaje, 7 fosas.

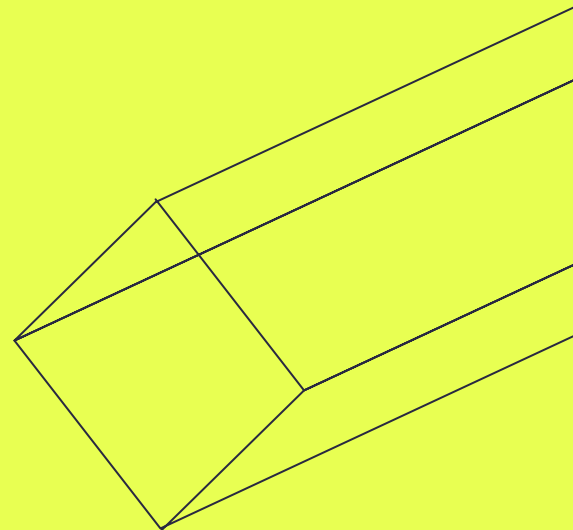

UNIVERSIDAD NACIONAL AUTÓNOMA DE MÉXICO



Dr. Leonardo Lomelí Vanegas
Dra. Patricia Dolores Dávila Aranda
Mtro. Hugo Alejandro Concha Cantú
Mtro. Tomás Humberto Rubio Pérez
Dra. Diana Tamara Martínez Ruíz
Lic. Raúl Arcenio Aguilar Tamayo
Mtro. Néstor Martínez Cristo

RECTOR
SECRETARIA GENERAL
ABOGADO GENERAL
SECRETARIO ADMINISTRATIVO
SECRETARIA DE DESARROLLO INSTITUCIONAL
SECRETARIO DE PREVENCIÓN Y SEGURIDAD UNIVERSITARIA
DIRECTOR GENERAL DE COMUNICACIÓN SOCIAL

ESCUELA NACIONAL COLEGIO DE CIENCIAS Y HUMANIDADES



Dr. Benjamín Barajas Sánchez
Lic. Mayra Monsalvo Carmona
Lic. Rocío Carrillo Camargo
Lic. María Elena Juárez Sánchez
QBP. Taurino Marroquín Cristóbal
Mtra. Dulce María E. Santillán Reyes
Mtro. José Alfredo Núñez Toledo
Mtra. Araceli Mejía Olguín
Lic. Héctor Baca Espinoza
Ing. Armando Rodríguez Arguijo

DIRECTOR GENERAL
SECRETARIA GENERAL
SECRETARIA ADMINISTRATIVA
SECRETARIA ACADÉMICA
SECRETARIO DE SERVICIOS DE APOYO AL APRENDIZAJE
SECRETARIA DE PLANEACIÓN
SECRETARIO ESTUDIANTIL
SECRETARIA DE PROGRAMAS INSTITUCIONALES
SECRETARIO DE COMUNICACIÓN INSTITUCIONAL
SECRETARIO DE INFORMÁTICA

Mtra. Martha Patricia López Abundio
Mtra. Patricia Trejo Martínez
MVZ. Genaro Romero González
Lic. Veidy Salazar De Lucio
Mtra. Noemí Jiménez Martínez
Lic. Antonio Nájera Flores
Mtra. Evelia Morales Domínguez
C. Adriana Astrid Getsemaní Castillo Juárez
Lic. Martha Contreras Sánchez
Lic. Verónica Andrade Villa

Mtro. Keshava Quintanar Cano
Mtra. Verónica Berenice Ruiz Melgarejo
Lic. Teresa De Jesús Sánchez Serrano
Ing. Damián Feltrín Rodríguez
Lic. Elizabeth Hernández López
Biól. María del Rosario Rodríguez García
Mtro. Josué David Sánchez Hernández
Lic. Ana Rocío Alvarado Torres
Ing. María del Carmen Tenorio Chávez
Lic. Reyna I. Valencia López

Lic. Maricela González Delgado
Ing. Manuel Odilón Gómez Castillo
Lic. Diana Reyna Alatorre Hernández
Mtra. María Xóchitl Megchún Trejo
Lic. María del Rosario Sánchez Sánchez
Lic. Armando Segura Morales
Lic. Carlos Ortega Ambriz
IQ. Georgina Guadalupe Góngora Cruz

Mtra. Patricia García Pavón
Qfb. Reyes Flores Hernández
Mtra. Alejandra Barrios Rivera
Mtra. Martha Maya Téllez
Mtra. Cecilia Espinosa Muñoz
Dra. Elsa Rodríguez Saldaña
Mtra. Claudia Verónica Morales Montañó
Ing. Angélica Nohelia Guillén Méndez

Lic. Susana de los Ángeles Lira de Garay
Lic. Noé Israel Reyna Méndez
Lic. Alfredo Saúl Montes Granados
Mtro. Ernesto Márquez Fragoso
Mtro. Armando Moncada Sánchez
Dra. Georgina Balderas Gallardo
Mtro. Reynaldo Cruz Contreras
Mtra. Nohemí Claudia Saavedra Rojas
Mtra. Clara León Ríos

AZCAPOTZALCO

DIRECTORA
SECRETARIA GENERAL
SECRETARIO ADMINISTRATIVO
SECRETARIO ACADÉMICO
SECRETARIA DOCENTE
SECRETARIO DE SERVICIOS ESTUDIANTILES
SECRETARIA DE SERVICIOS DE APOYO AL APRENDIZAJE
JEFA DE LA UNIDAD DE PLANEACIÓN
SECRETARIA TÉCNICA DEL SILADIN
SECRETARIA PARTICULAR Y DE GESTIÓN

NAUCALPAN

DIRECTOR
SECRETARIA GENERAL
SECRETARIA ADMINISTRATIVA
SECRETARIO ACADÉMICO
SECRETARIA DOCENTE
SECRETARIA DE SERVICIOS ESTUDIANTILES
SECRETARIO DE APOYO AL APRENDIZAJE Y CÓMPUTO
SECRETARIA DE ADMINISTRACIÓN ESCOLAR
SECRETARIA TÉCNICA DEL SILADIN
COORDINADORA DE GESTIÓN Y PLANEACIÓN

VALLEJO

DIRECTORA
SECRETARIO GENERAL
SECRETARIA ADMINISTRATIVA
SECRETARIA ACADÉMICA
SECRETARIA DOCENTE
SECRETARIO DE ASUNTOS ESTUDIANTILES
SECRETARIO DE SERVICIOS DE APOYO AL APRENDIZAJE
SECRETARIA TÉCNICO DEL SILADIN

ORIENTE

DIRECTORA
SECRETARIO GENERAL
SECRETARIA ADMINISTRATIVA
SECRETARIA ACADÉMICA
SECRETARIA DOCENTE
SECRETARIA DE ASUNTOS ESTUDIANTILES
SECRETARIA DE ADMINISTRACIÓN ESCOLAR
SECRETARIA TÉCNICA DEL SILADIN

SUR

DIRECTORA
SECRETARIO GENERAL
SECRETARIO ADMINISTRATIVO
SECRETARIO ACADÉMICA
SECRETARIO DOCENTE
SECRETARIA DE ASUNTOS ESTUDIANTILES
SECRETARIO DE APOYO AL APRENDIZAJE
SECRETARIA TÉCNICO DEL SILADIN
JEFA DE LA UNIDAD DE PLANEACIÓN



COORDINACIÓN
Rocío Carrillo Camargo

SUPERINTENDENTE DE OBRAS
Carlos Alejandro Pérez Escalante

JEFE DE DEPARTAMENTO
Abraham Isaac Sosa Romero

RESIDENTES
AZCAPOTZALCO
Diyand Natalisse Martínez Lara

NAUCALPAN
Ezequiel Ayala Agilar

VALLEJO
Alejandra de Jesús Flores Briones

ORIENTE
Israel Araiza Nava

SUR
Roberto Carlos Gaspar

JEFE DE ÁREA
Rafael Avilés López

ASISTENTE
Leticia Torres Gutiérrez

REVISIÓN
Benjamín Barajas Sánchez
Marcos Daniel Aguilar

EDICIÓN
Héctor Baca Espinoza

DISEÑO
Elena Pigenutt

CORRECCIÓN
Bernardino Mérida Yáñez